

LDDC Series

Double-Deck Drum Pre-cleaner

# Instruction Manual



**LAMBTON MACHINERY (ZHENGZHOU) CO. LTD.**

**2015.08**



## Index

Double-Deck Drum Pre-cleaner .....	1
Instruction Manual .....	1
I . General Introduction .....	3
II . Main Parameters shown as Table 1 and Table 2.....	3
III. Main Structure(Figure-1) .....	5
IV. Operating Principles and Processes .....	6
V . Installation .....	7
VI. Installation Dimensions.....	9
VII. Operation and Maintenance .....	10
VIII. Trouble shooting.....	13

## I . General Introduction

LDDC Drum Pre-cleaner is newly designed equipment by our company used for grain and oil processing industry. It has double cylinder screen drums, featured with adjustable incline angle. It can be adjusted in an available range of incline angle in line with the required capacity and processing effect to regulate the speed that the materials moves forward in the screen drum.

In accordance with the principles of being useful, applicable and durable, LDDC Drum Pre-cleaner is designed to have nice appearance, rational structure and convenient operation and maintenance. It has many advantages including large volume, high efficiency, low power consumption, favorable cleaning, stable transmission and low noise; and also the suction device installed with the machine can remove fine impurities and dust in the grain, as well as other impurities.

## II . Main Parameters shown as Table 1 and Table 2.

**Table 1**

Parameter Type	Mode					
	LDDC 85/190	LDDC 100/220	LDDC 100/320	LDDC 100/420	LDDC 125/320	LDDC 125/420
RPM (r/min)	16	14	14	14	12	12
Power (kw)	1.5	2.2	4	5.5	4	5.5
Fan power (kw)	3	5.5	5.5	7.5	7.5	7.5
Volume (m <sup>3</sup> /h)	4000	5500	6500	8000	7500	9500
Coarse impurity rate (%)	› 96%					
Fine impurity rate (%)	› 92%					

**Table 2**

Material	Parameter	Mode Capacity(T/h)	LDDC	LDDC	LDDC	LDDC	LDDC	LDDC
			85/190	100/220	100/320	100/420	125/320	125/420
Wheat	Inner Mesh Dia. (mm)	φ22	60	80	110	140	140	170
		φ20	50	70	100	120	120	150
		φ18	40	60	90	110	100	120
		φ16	30	50	70	100	90	110
	Out Mesh Dia.(mm)	φ1.8-φ3.2						
Corn	Inner Mesh Dia. (mm)	φ24	60	85	110	150	150	170
		φ22	50	75	100	130	120	150
		φ20	40	65	90	110	110	130
		φ18	30	50	80	100	100	120
	Out Mesh Dia. (mm)	φ4.5-φ6.5 (Based on corn moisture and ground pellet content)						
Soybean	Inner Mesh Dia. (mm)	φ24	70	85	120	150	150	180
		φ20	60	75	100	140	130	160
		φ18	50	65	80	120	110	150
		φ16	40	50	70	110	100	140
	φ14	30	40	60	100	90	120	
Out Mesh Dia. (mm)	φ2.5-φ5 (Based on soybean moisture and ground pellet content)							
Paddy Rice	Inner Mesh Dia. (mm)	φ24	40	60	90	120	110	140
		φ22	35	50	70	100	90	120
		φ20	30	40	60	80	80	100
	Out Mesh Dia. (mm)	φ1.6-φ2.5						

**Notes:** The inner mesh can be made into different types based on customer's requirement, such as round, square or Hexagonal etc. It is only round in above tables.

### III. Main Structure (Figure 1)

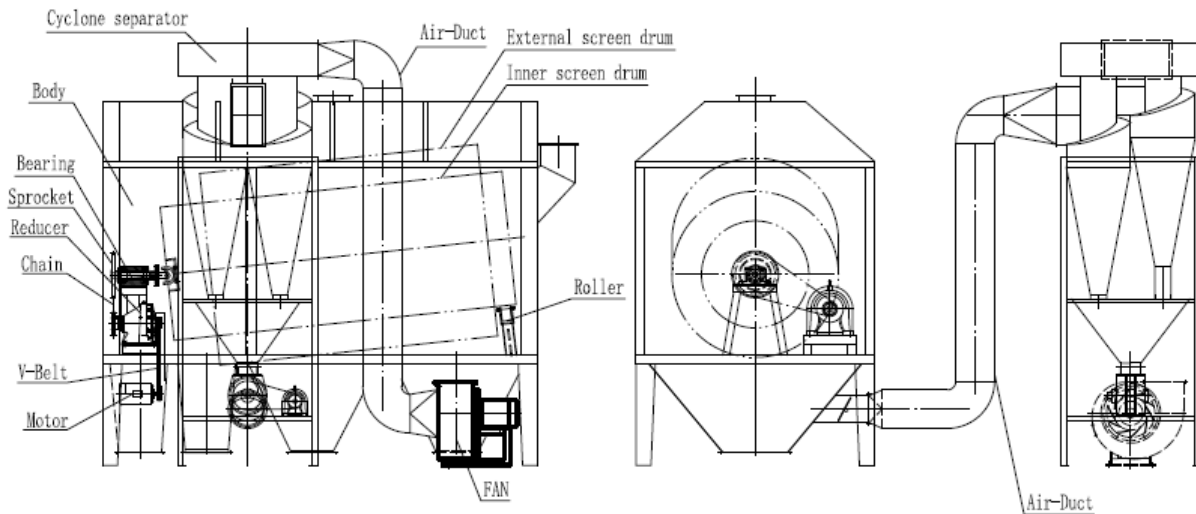

**Figure 1**

#### 1. Driving mechanism

The driving mechanism of Drum Pre-cleaner consists of reducer, sprocket, and chain, cross shaft universal coupler, double drums and support rollers. The double drums are assembled into a whole unit by connecting the internal and external screen drum with coupling rod. The support roller is installed on adjustable support framework on one side of the screen drum to support the screen drum rotation and adjust the inclination; the other side is connected with the cross shaft universal coupler to freely alter the inclination of screen drum.

#### 2. Body of machine

The Drum Pre-cleaner body consists of the frame, side and end sealing doors. The frame is welded with the high grade steel, one of its middle pillar, right side if you face to motor which bolts to the frame, is bolted to the frame in order to easily disassemble the screen drum; the side and end sealing doors are processed with high grade steel by NC laser cutting machine and NC brake. The whole body is nice, solid and has good sealing performance.

#### 3. Sieve cleaning mechanism

The sieve cleaning mechanism is a rectangle brush which has been

processed with chemicals. The brush is hard to break and can efficiently clear the materials and impurities blocked in the mesh of external screen drum, ensuring smooth cleaning and good cleaning effect to fine impurities.

#### 4. Dust removal mechanism

The dust removal mechanism is mainly composed of fan and suction pipe, cyclone. It is used to clear up the dust and fine impurities in the grain by negative pressure from the fan. The air volume is different based on various material and can be adjusted by the door installed in the air duct.

### IV. Operating Principles and Processes

#### 1. Operating principles

LDDC Drum Pre-cleaner works with the principles of sizes difference of grain and impurity particles, separating coarse impurities bigger than inner mesh and fine impurities smaller than outer mesh from grain by continuous rotating screens. The air suction device is used to clear up the dust and slight impurities blown into the materials so as to get the materials cleaned effectively.

#### 2. Cleaning processes

Figure 2 shows the cleaning process. During LDDC Drum Pre-cleaner operation, the grain to be cleaned flows into the internal screen drum and gets the continuous sifting through the rotation of screen drum, so as to make the grain and impurities smaller than inner mesh size falling into the external screen drum, while the impurities bigger than inner mesh size will be left in the inner screen drum, then the impurities smaller than outer mesh size will fall into fine impurity outlet, the grain left in the outer screen drum and impurities left in the internal screen drum are pushed forward to flow into the grain hopper and big impurity outlet with the rotation of screen drum. The fine impurities and dust wrapped into grain are sucked by the cyclone through the air path.

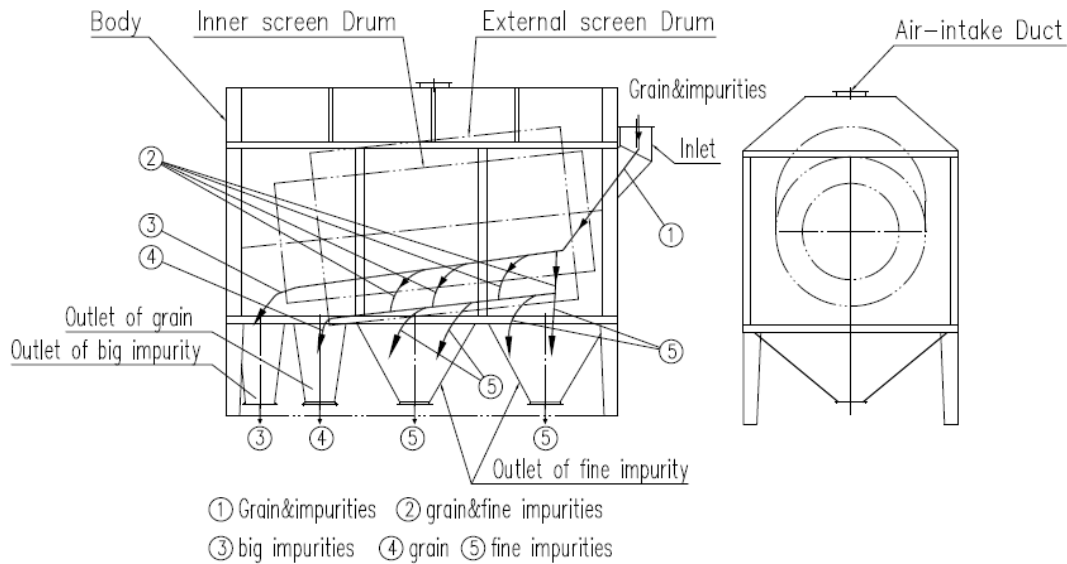

Figure 2

## V. Installation

1. Check if any loosening or damage of the parts of machines suffered from the transportation and carrying before the installation, and refuel or oil the reducer and other rotating parts
2. Foundation requirement. The location tolerance on the surface is  $\pm 2$  mm, and the height varies no more than  $\pm 1$  mm.
3. In order to easy operation and maintenance, the sufficient space should be given around the machine (about 1.8m on bolted shell side)
4. Lay down the bottom of drum cleaner on the foundation, and check the level of degree.
5. Put some rubber between the legs and foundation to reduce the vibration if it is possible.
6. Remove the temporary brace of the upper part of the machine body, and assemble the upper body with lower body through bolts within the

square pipe. Make sure the two pieces together without gap.

7. Install the triangle belt for transmission.

8. Install cyclone, air fan, air lock and air duct. When the air duct is installed, make sure the pipe is at horizontal or vertical directions, avoid the inclined air pipe. Use as few as possible elbow.

9. Screen inclination adjustment (see figure 3). To protect the machine, before shipment the rollers are moved as far as possible, and the drum can sit on the frame of machine base. After receiving the equipment, customer needs to adjust the screen drum at right position and right inclined angle. First use brace to temporarily support the screen drum. The next step is to adjust the roller lock nuts positions, and make sure rollers are symmetric about the center of the screen drum, as shown blue lines. The symmetric positions of the roller are designed at when the bolts are located at the center of slot. After this, put the screen drum on the roller, and check the symmetry again. The inclination angle of the drum can be adjusted by changing the distance of the two rollers.

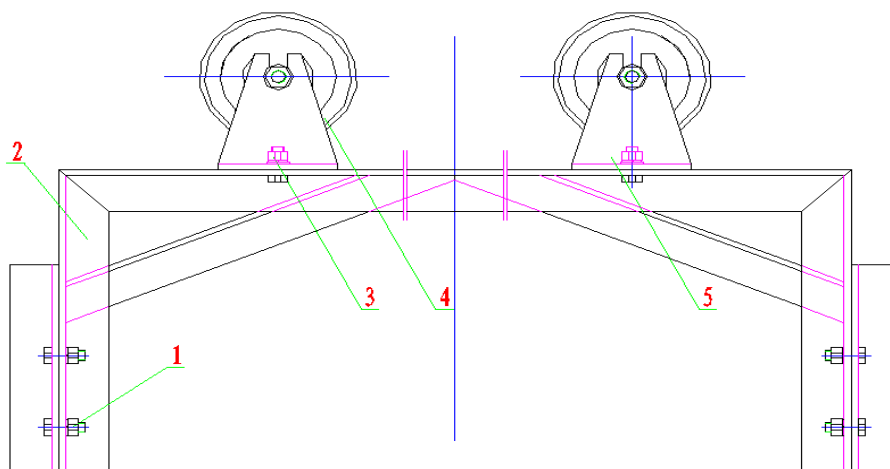

1. Lock nuts 2.Adjustable support 3.Roller lock nuts 4. Support roller 5. Roller support  
Layout of Screen Inclination Adjustment

Figure 3



### VI. Installation Dimensions

LDDC series Type B Double Drum Pre-cleaner dimensions as attached layouts.

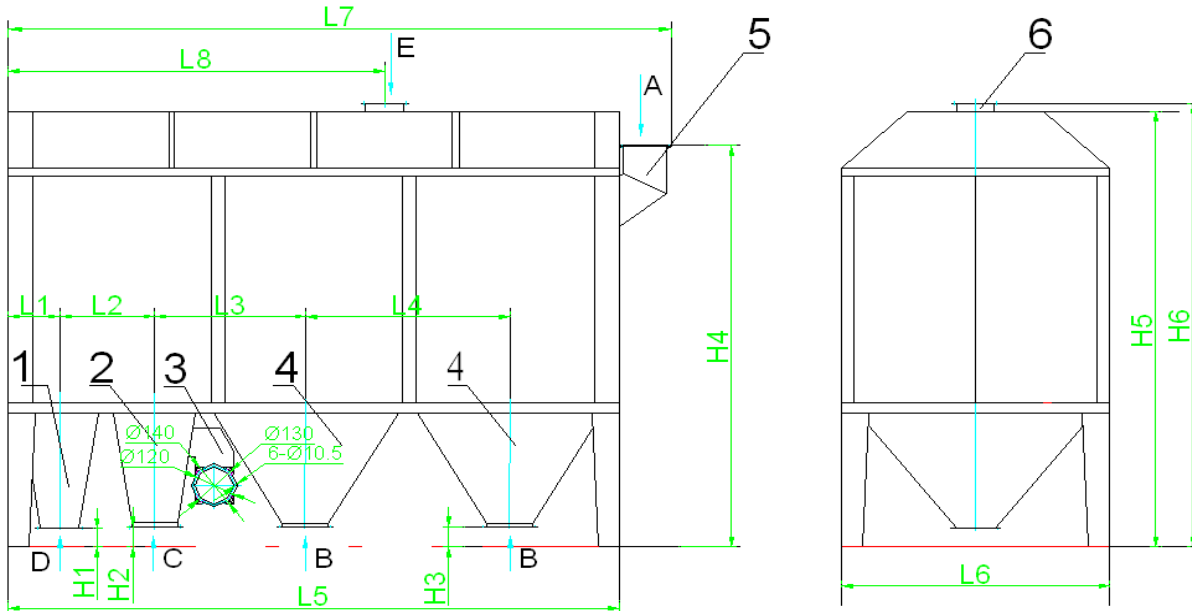

1.Outlet of large impurity 2.Grain Outlet 3.Bottom Air-intake Duct  
 4.Outlet of fine impurity 5.Grain Inlet 6.Top Air-intake Duct  
 (Notes:LDDC85/190、100/200 have only one outlet of fine impurity )  
 Layout of LDDC Series Double-Deck Drum Pre-cleaner

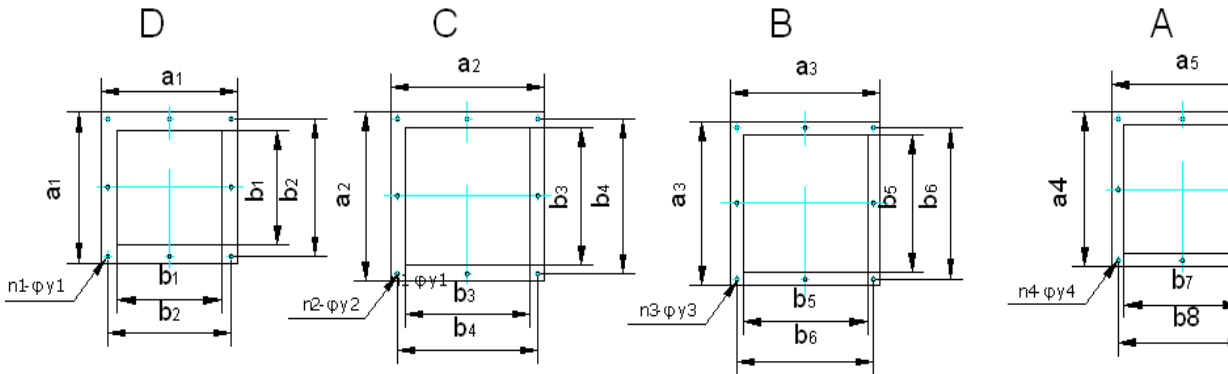

Anchor Bolt Holes

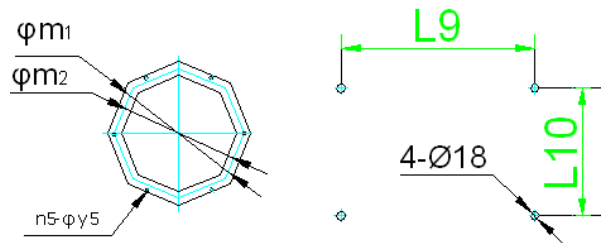

Inlet & outlet layout of LDDC series Double-Deck Drum Pre-cleaner

**Table 3 LDDC Series Drum Pre-cleaner Dimensions**

Model	L <sub>1</sub>	L <sub>2</sub>	L <sub>3</sub>	L <sub>4</sub>	L <sub>5</sub>	L <sub>6</sub>	L <sub>7</sub>	L <sub>8</sub>	L <sub>9</sub>	L <sub>10</sub>
85/190	365	513	956		2640	1470	2950	1320	2500	1330
100/220	344	581	1210		3100	1620	3410	1550	2960	1480
100/320	340	626	995	1351	4040	1770	4380	2490	3900	1630
100/420	430	750	1200	1800	5200	1900	5600	3050	5080	1780
125/320	350	620	980	1350	4050	2220	4680	2150	3950	2070
125/420	430	750	1200	1800	5200	2220	5600	3050	5070	2070

**Table 4 LDDC Series Drum Pre-cleaner Dimensions**

Model	b <sub>1</sub>	b <sub>2</sub>	b <sub>3</sub>	b <sub>4</sub>	b <sub>5</sub>	b <sub>6</sub>	b <sub>7</sub>	b <sub>8</sub>	b <sub>9</sub>	b <sub>10</sub>
85/190	200	230	250	280	300	330	250	280	250	280
100/220	250	280	260	290	300	330	250	280	300	330
100/320	300	330	300	330	300	330	280	310	280	310
100/420	300	330	300	330	300	330	320	350	320	350
125/320	300	330	300	330	300	330	320	350	320	350
125/420	300	330	300	330	300	330	320	350	320	350

**Table 5 LDDC Series Drum Pre-cleaner Dimensions**

Model	a <sub>1</sub>	a <sub>2</sub>	a <sub>3</sub>	a <sub>4</sub>	a <sub>5</sub>	H <sub>1</sub>	H <sub>2</sub>	H <sub>3</sub>	H <sub>4</sub>	H <sub>5</sub>	H <sub>6</sub>
85/190	260	310	360	310	310	130	130	130	2230	2430	2490
100/220	310	320	360	360	310	140	140	140	2430	2620	2680
100/320	360	360	360	340	340	140	140	140	2800	3003	3060
100/420	360	360	360	380	380	120	120	120	2800	3100	3160
125/320	360	360	360	380	380	120	120	120	3000	3400	3460
125/420	360	360	360	380	380	120	120	120	3050	3600	3660

**Table 6 Inlet, Outlet and Air intake Dimensions**

Model	n <sub>1</sub> -φy <sub>1</sub>	n <sub>2</sub> -φy <sub>2</sub>	n <sub>3</sub> -φy <sub>3</sub>	n <sub>4</sub> -φy <sub>4</sub>	n <sub>5</sub> -φy <sub>5</sub>	φm <sub>1</sub>	φm <sub>2</sub>
85/190	8-φ7	8-φ7	8-φ7	8-φ9	4-φ7	φ230	φ200
100/220	8-φ9	8-φ9	8-φ9	8-φ9	6-φ7	φ280	φ250
100/320	8-φ9	8-φ9	8-φ9	8-φ9	6-φ7	φ280	φ250
100/420	12-φ9	12-φ9	12-φ9	12-φ9	6-φ7	φ280	φ250
125/320	12-φ9	12-φ9	12-φ9	12-φ9	6-φ7	φ280	φ250
125/420	12-φ9	12-φ9	12-φ9	12-φ9	6-φ7	φ280	φ250

## VII. Operation and Maintenance

1. Before running the machine, please check the fastening, safety guard, and lubrication.

2. First time running, please check the driving system, the rotation direction of screen drum and air fan.

3. The drum rotation direction should be identical with the internal signs of the machine, or else it will damage the sieve cleaning mechanism.

4. When testing running, it should be run empty with one to two hours, check if there is no any abnormalities in temperature and noise, then put into the materials.

5. Figure 4 shows the 4 main components of the machine. They are pre-cleaner, fan, cyclone and air lock. Strictly follow the operational process as:

When starting the machine, turning on the air lock, and then air fan, and finally drum. Start to feed the material only when machine runs well. The machine has to start without loading. The feeding speed should be controlled with certain limit.

When turning off the machine, stop feeding first, when all the material are cleaned in the drum and the drum can be turned off. Then turn off the air fan, finally turn off the air lock.

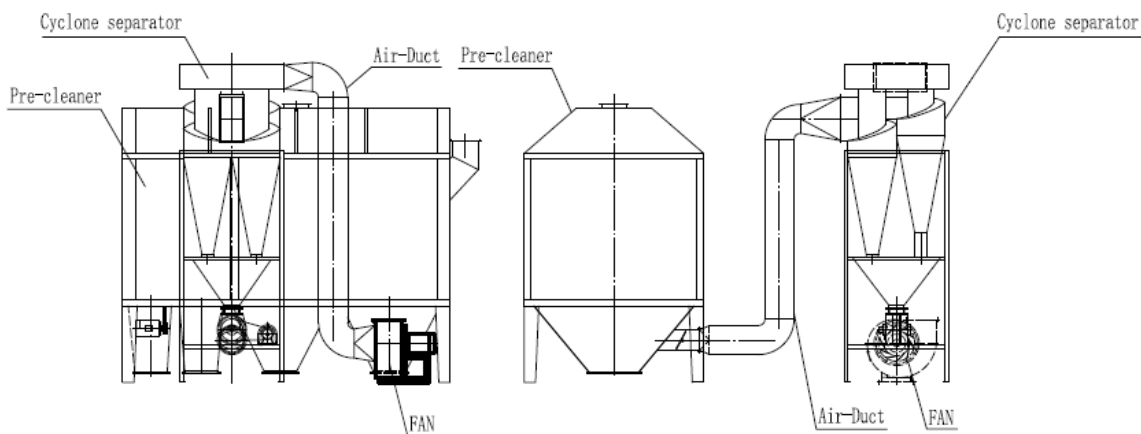

Figure 4

6. The brush used for screen surface cleaning should be examined whether it touches to the screen surface before starting the machine; if the cleaning brush is away from the screen surface, should find out the reason and solve it.

7. The rollers are used to support the drums. Routine check the rotation of the roller, make sure the good lubrication to reduce the worn.

8. The drum should rotate around the central line without shift.

9. The capacity of the machine can be adjusted trough changing the distance of roller. The far distance of roller will cause big inclination of the drum, which will increase the capacity. The small distance of the roller will cause small inclination of the drum, which will decrease the capacity.

10. The adjustment of the inclination is shown as attached layout (Figure 3). The screen angle has been adjusted before leaving the factory, if it needs to be adjusted, please use the frame temporarily to support the drum, and move the double drum away from the support roller. It can be adjusted with two methods: one is to change the positions of the adjustable supports up and down. The adjustable supports can be moved along the slot. Loose the lock nuts, and move to the right height, and lock it. Another way is to adjust the distance of roller by moving the two roller lock nuts, but be make sure the drum is symmetric about the central line

11. First time run the machine, please put the bottom air intake at the maximum position, as shown in Figure 5. If there is some grain discharging from the air lock, please reduce the air intake, until there is no grain leaking, and fix the air intake adjustment plate.



Figure 5

12. Regularly inspect the parts with frequent rotation and heavy load; maintain in time if any abnormal occurs.

13. The machine should be routine checked. Universal adjusting mechanism is required to infuse calcium grease once quarterly; reducer and fan should be used and maintained in line with the requirement of supplier's instructions. Other rotating parts should be lubricated once every half year.

14. After newly installation or maintenance, please ensure the consistency of the fan rotation with the external signs on the shell, the screen rotation with the internal signs of machine.

### VIII. Trouble shooting

Problems	Analysis	Solutions
Bad cleaning quality	<ul style="list-style-type: none"> <li>▪ The sieve is broken</li> <li>▪ Feeding is too fast</li> <li>▪ Size of sieve and hole do not match</li> <li>▪ Inclination of drum is too big</li> </ul>	<ul style="list-style-type: none"> <li>▪ Change the sieve or repair</li> <li>▪ Reduce the feeding speed</li> <li>▪ Replace with right sieve</li> <li>▪ Adjust to bigger inclination</li> </ul>
Less capacity	<ul style="list-style-type: none"> <li>▪ Slow feeding</li> <li>▪ Holes of sieve are blocked</li> <li>▪ Rotation speed is low</li> <li>▪ Inclination of drum is too small</li> </ul>	<ul style="list-style-type: none"> <li>▪ Increase feeding speed</li> <li>▪ Check the brush</li> <li>▪ Check the transmission system</li> <li>▪ Change the drum angle</li> </ul>
Noise and vibration	<ul style="list-style-type: none"> <li>▪ No or less lubrication on bearing</li> <li>▪ Bolts are loosing</li> </ul>	<ul style="list-style-type: none"> <li>▪ Lubricate on bearing</li> <li>▪ Check and tighten the bolts</li> </ul>
Cannot start	<ul style="list-style-type: none"> <li>▪ Material stuck in the drum</li> <li>▪ Electronic problem</li> </ul>	<ul style="list-style-type: none"> <li>▪ Clean the drum</li> <li>▪ Check the electronics.</li> </ul>
Overheating of bearing	<ul style="list-style-type: none"> <li>▪ No or less lubrication on bearing</li> </ul>	<ul style="list-style-type: none"> <li>▪ Lubricate on bearing</li> </ul>