



**One Source...
One Solution!**

**Dual Inlet Pendulum
Installers Manual**



Lambton Conveyor

1247 Florence Road Florence
Ontario, N0P 1R0

Canada

1 - 888 - 239 - 9713

www.lambtonconveyor.com



**One Source...
One Solution!**

Table of Contents

Installers Manual

Invisible Button.....	P1
Inlet A Set Up	P2
Prox Set Up	P2
Motor Set Up	P2
Encoder Set Up	P3
Inlet B Set Up.....	P4
Cross Wire Detection.....	P5

Lambton Conveyor

1247 Florence Road Florence

Ontario, N0P 1R0

Canada

1 - 888 - 239 - 9713

www.lambtonconveyor.com



**One Source...
One Solution!**

Invisible Button - Set up Mode Installers Manual



Invisible Button

Press here to get into
the set up mode

This screen is the first screen that is displayed when the control unit is energized.

Invisible Button

In the top right corner press the screen this will take you into the set up mode.

A red screen will appear then select which Inlet you wish to set up



One Source...
One Solution!

Inlet A Set Up Installers Manual

Push "Set A" to be set up Inlet A



Step 1 Prox Set up

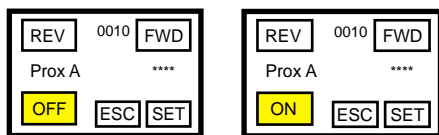

Move the arm to the middle over the home position prox, when this occurs the "OFF" button will switch to "ON"
If not see prox setup page

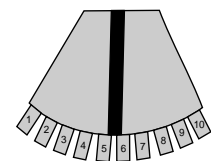

Then move to next step

Step 2 Motor Set up Press REV the arm should move towards Port 1

Note: If the arm is moving in the wrong direction, cross motor leads.
Then repeat Step 2

If OK move to next step

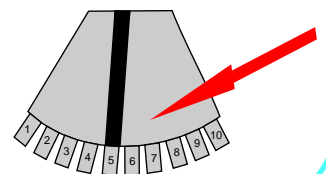



One Source...
One Solution!

Inlet A Set Up Installers Manual

Step 3 Encoder Set up When pressing REV the Encoder numbers should be counting down
If OK move to next step

(If the Encoder Value is negative the Encoder Value will appear to be going up) See Fig. below

Note: If the Encoder values are counting in the wrong direction, cross wires X0 and X1
Then repeat Step 3

Example the Encoder values below are counting down but appear to be increasing

Notice the minus sign

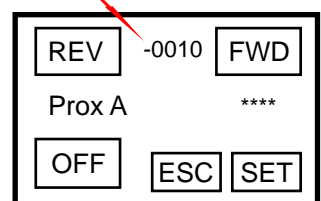
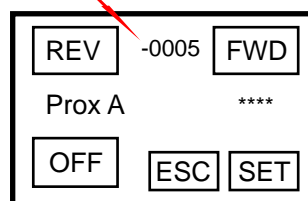
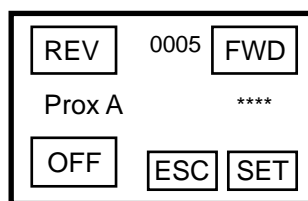
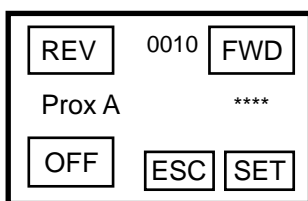

Step 4 Push and hold FWD move the arm to Port 7 (should pass the home position prox)

Now see test page

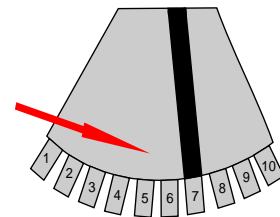

Do not push the **Set** button use the **ESC**



One Source...
One Solution!

Inlet B Set Up Installers Manual

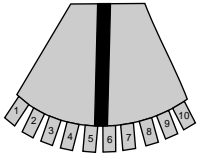

Step 1

Prox Set up

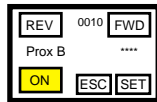
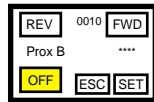

Move the arm to the middle over the home position prox, when this occurs the "OFF" button will switch to "ON"

If not see prox setup page

Then move to next step

Step 2

Motor Set up

Press REV the arm should move towards Port 1

Note: If the arm is moving in the wrong direction, cross motor leads. Then repeat Step 2

If OK move to next step

Step 3

Encoder Set up

When pressing REV the Encoder numbers should be counting down

If OK move to next step

Please look for the minus sign

(If the Encoder Value is negative the Encoder Value will appear to be going up) See Fig below

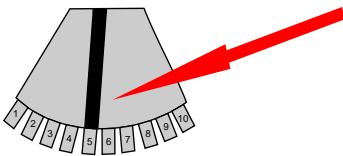

Note: If the Encoder values are counting in the wrong direction, cross wires X3 and X4 Then repeat Step 3

Example the Encoder values below are counting down but appear to be increasing

Please look for the minus sign

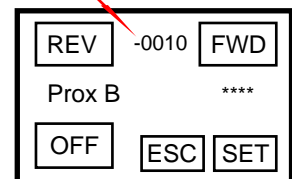
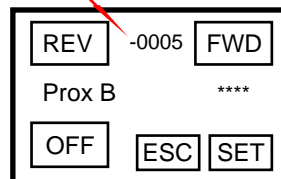
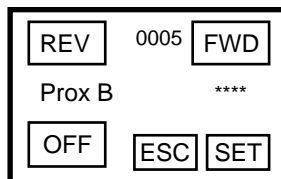
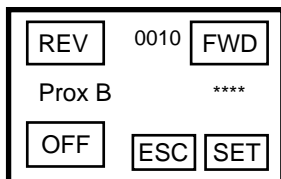

Do not push the **Set** button use the **ESC**



**One Source...
One Solution!**

Installers Manual

Errors

Cross Wire Detection

When you see this screen the motor or the encoder has been wired incorrectly.

Please notice if Port A or Port B error

Refer to pages

P2 - Verifying Motor Direction

P3 - Verifying Encoder Direction

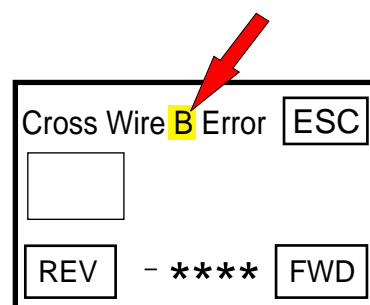
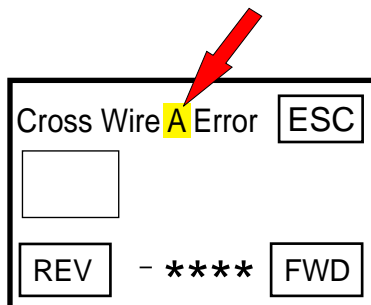

Lambton Conveyor

1247 Florence Road Florence
Ontario, N0P 1R0
Canada

1 - 888 - 239 - 9713

www.lambtonconveyor.com

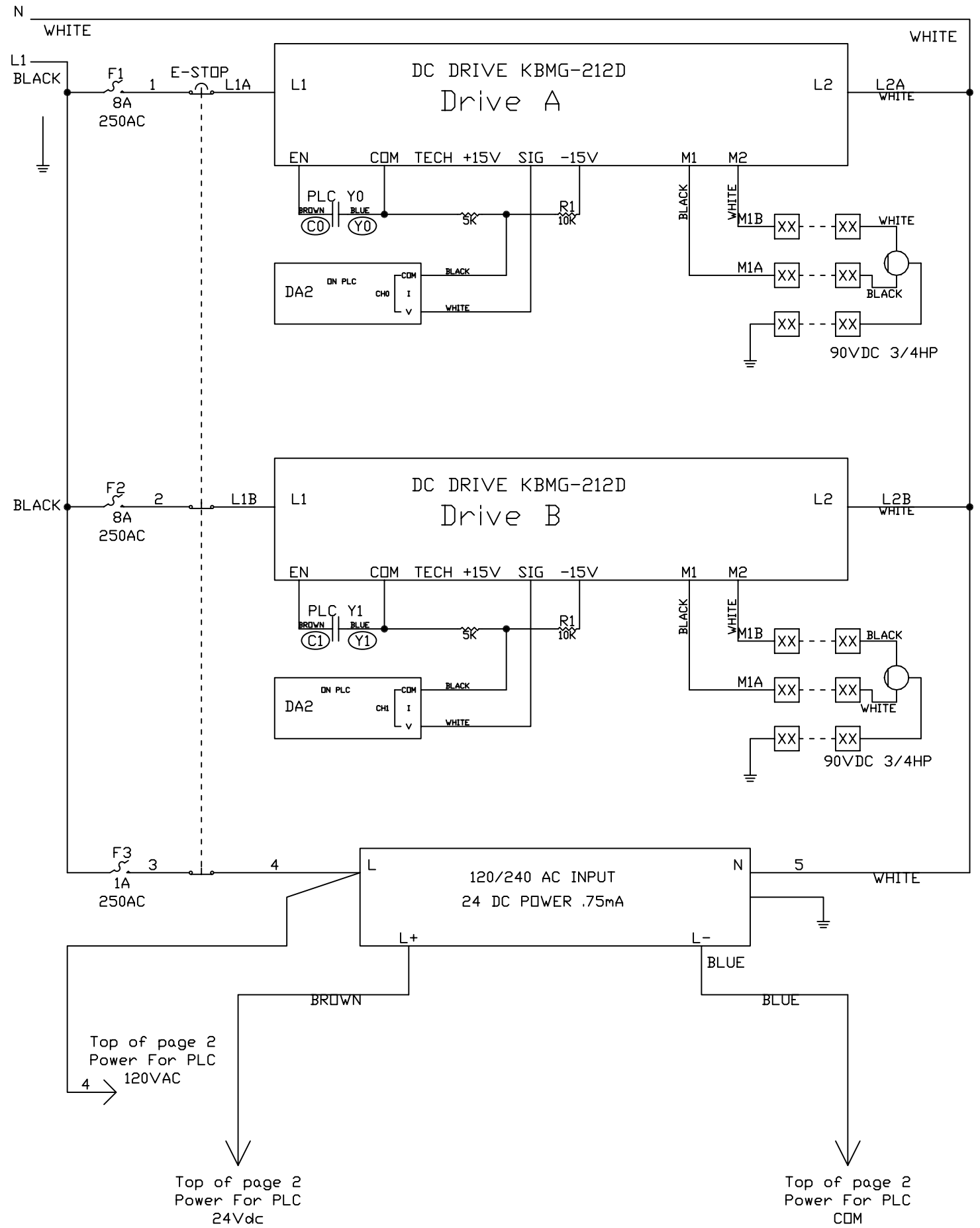

BY: SADHU GILL

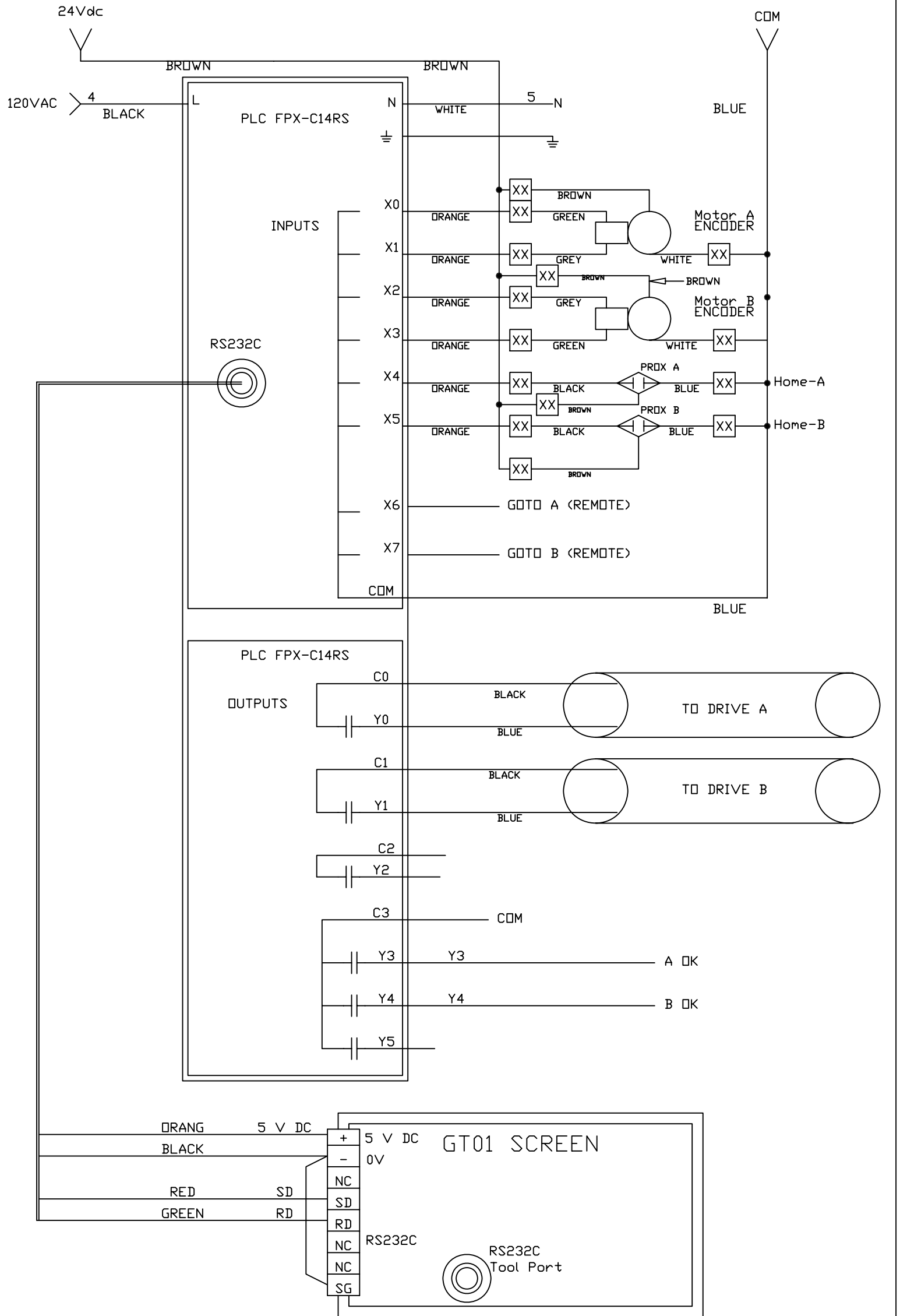

REMOTE IN/OUTPUTS

ALL INPUTS
24VDC
PNP or NPN

24Vdc

COM

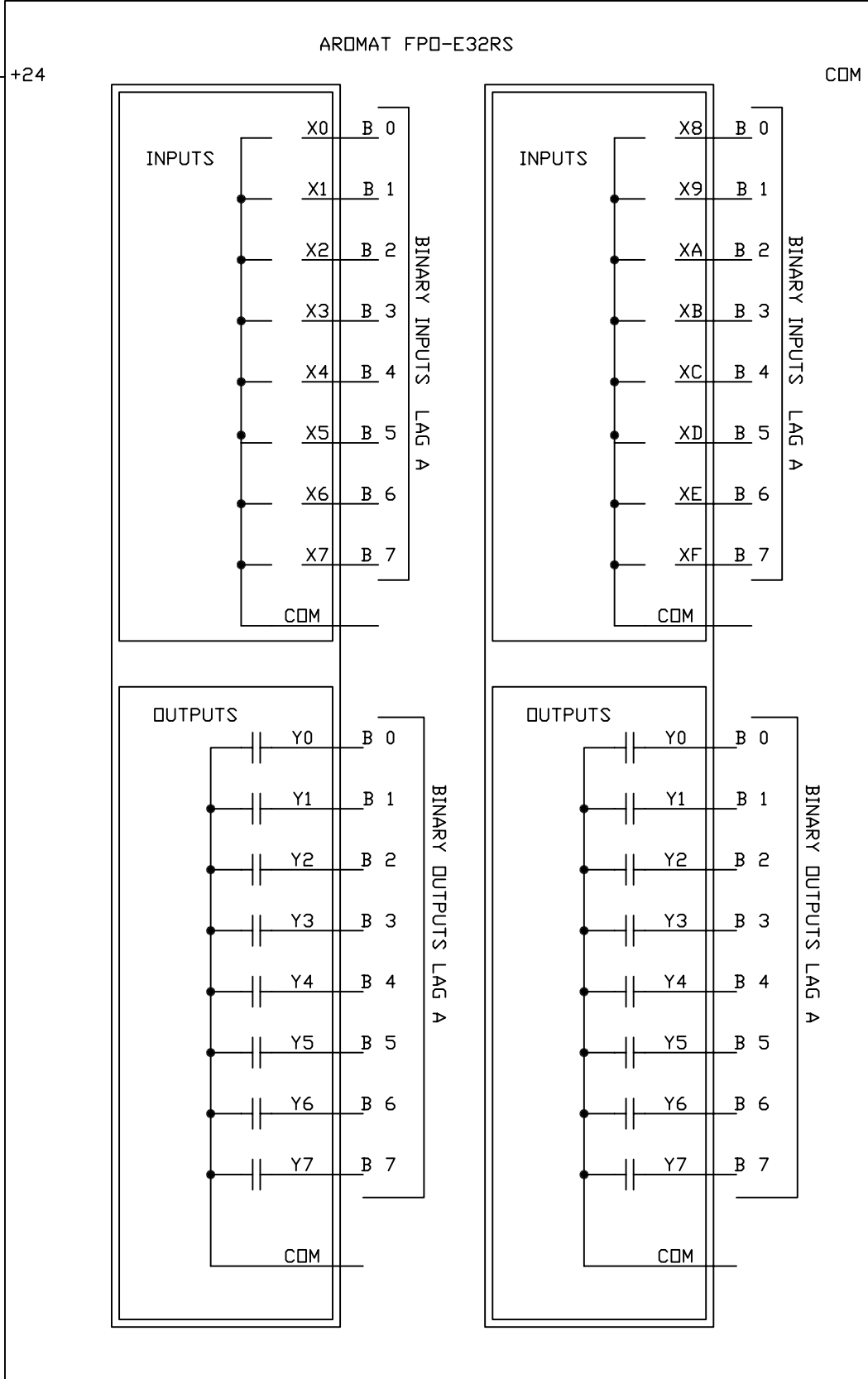

All outputs are
Relays 250Vac 2amp