

Platform Manual

5" 4X3



LAMBTON CONVEYOR LIMITED

102 Arnold Street
Wallaceburg, ON N8A 3P4
Canada



ONE SOURCE • ONE SOLUTION

Telephone: (519) 627-8228
Toll free: (888) 239-9713 (North America)
Fax: (519) 627-0250
www.lambtonconveyor.com

Revised: December 15, 2008

Table of Contents

Platform Placement **Pg. 3**

Head Service Platform **Pg. 4-10**

Platform Placement

Lambton Conveyor platforms have been specifically designed for placement on certain areas of the bucket elevator. Below is a list of the different types of platforms, their uses, and recommended placement. Any other use or placement aside from the ones mentioned below could result in serious injury or death.

Rest Platform

The Lambton Conveyor rest platform is intended to be used as a safety platform while climbing the elevator to prevent serious injury in the case of a fall. It is to be located every 20' for federal applications, or every 30' as a provincial standard. When standing a bucket elevator in two or more sections the rest platform should be mounted in an adequate position to allow for trunking to be connected (just below the joint).

Work Platform

The Lambton Conveyor work platform is intended to be mounted approximately 6' below the elevator distributor to the trunking and should be used for servicing the distributor and installing down spouts only. Due to various layouts it may be necessary to mount the platform lower in order to miss the distributor valves or spouting.

Head Service Platform

The Lambton Conveyor head service platform is intended to be mounted directly to the elevator head or just below the head with smaller elevators in order to service and repair problems with the head itself or drive assembly. The service platform is not intended to be used anywhere else on the elevator.

It is the owners/operators responsibility to ensure all unauthorized personnel are kept clear of these assemblies and that all workers/operators are aware of the necessary safety precautions.



Owners Installation Manual

5" Head Service Platform

The Lambton Conveyor head service platform is intended to be mounted directly to the elevator head or just below the head with smaller elevators in order to service and repair problems with the head itself or drive assembly. The service platform is not intended to be used anywhere else on the elevator.

The platform is designed to be mounted on either side of the head unit (depending on where the ladder is). Due to this, the pictures enclosed may not be an exact representation of your specific application.

The platform should be assembled on the motor, not distributor, side of head unit.

All connections are to be bolted with $\frac{5}{16}$ " x $\frac{3}{4}$ " long bolts with $\frac{5}{16}$ " hex nuts. Exception to this; in the case of the hinges and handle for the platform door, use the hardware supplied with them.

A parts list has been provided with a description and number of each individual part to make the assembly as easy as possible.

Step #1

At the desired location (suggest 3 ½ -4' below head), position the two 53" primary support C-channels (1). On the side of the trunk where the hem lock is located, the hem will have to be cut. This may be done with a hacksaw, then bend the hem back out of the way (a torch may also be used). The portion of hem to be moved should be approximately 3 ½ @ long (min.). Bolt the two C-channels together (one on either side to squeeze trunk) using the ¾ @ dia. Ready-rod supplied. Use the ¾ @ washers that are supplied also. After tightening the nuts, install the second set of nuts supplied so that each end of rod is double nut locked. We suggest welding the C-channel to the trunk to add further support and rigidity.

On top of the primary channels, bolt down the 46 5/16" secondary support C-channels (2). Use all holes (four bolts in each of the three channels). Orientate the channels that are on either side of the ladder as shown. On the inside of these two channels, bolt on the two 18" floor/door support angles (3). These angles should be bolted flush with the top of the C-channels, in the holes furthest from the trunk.

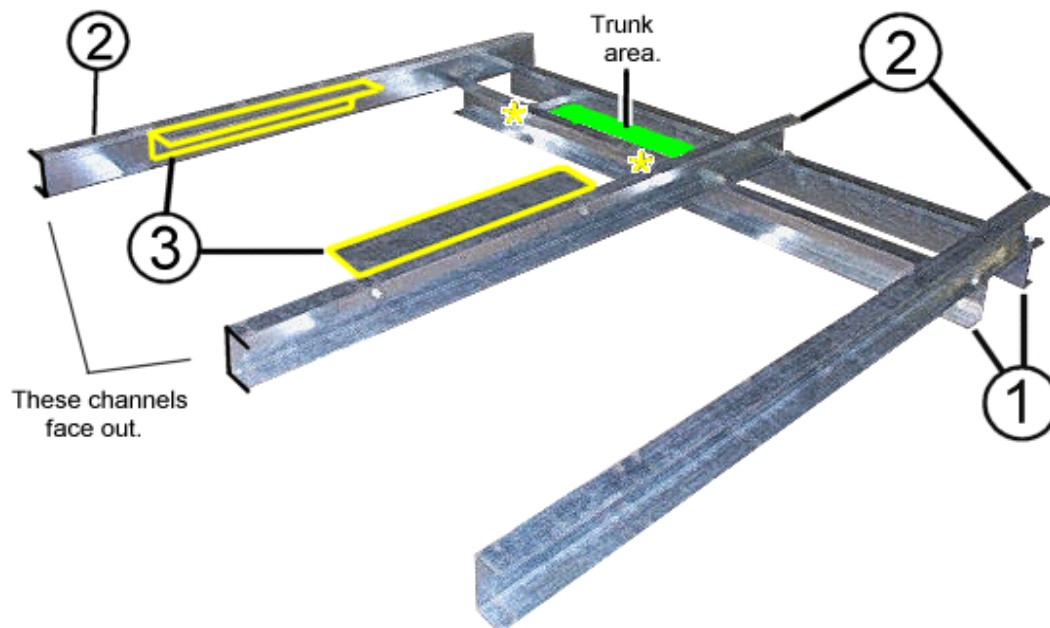

NOTE: □ These rods should be double nut locked.
The trunk is not shown but would be located in the area noted in the diagram.

Step #2

Position the $38 \frac{3}{8} \times 31 \frac{1}{2}$ @ doorframe panel (4). Position the $38 \frac{3}{8}$ @ door side toe board (5), the $51 \frac{1}{2}$ @ front toe board (6), the $25 \frac{5}{16}$ @ rear ladder toe board (7), the $7 \frac{1}{4}$ @ short ladder toe board (8), and the $14 \frac{5}{16}$ " long ladder toe board (9). Using the row of holes in the C-channel closest to the trunk, bolt through all holes in panel, through toe boards and through C-channel.

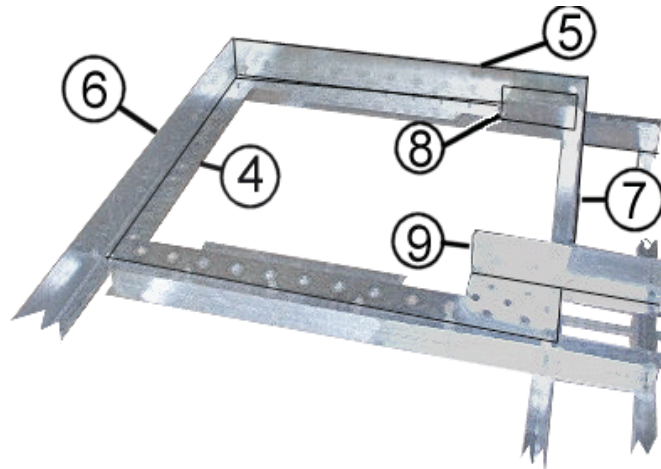

NOTE: □ Using these holes fasten the toe boards to the ladder channels. This will require either drilling holes in the ladder channels or welding the connection.

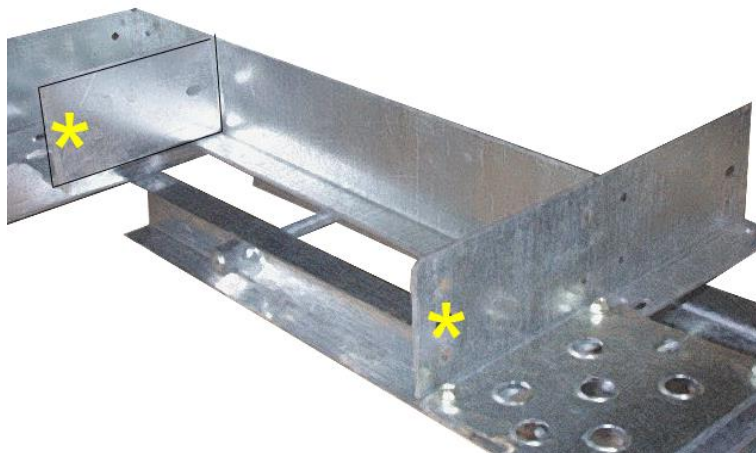

Step #3

Assemble the 27 ⁷/₈ @ x 25 ¹/₄ " door panel (10). Bolt on the 29" door toe board (11). Using the hardware provided in the hinge kit, bolt on the handle and the hinges. The hinges go on top of the door panel. On the underside of the door panel, use the 18 ³/₄ @ hinge stiffener (12). This will be held on with the hinge bolts.

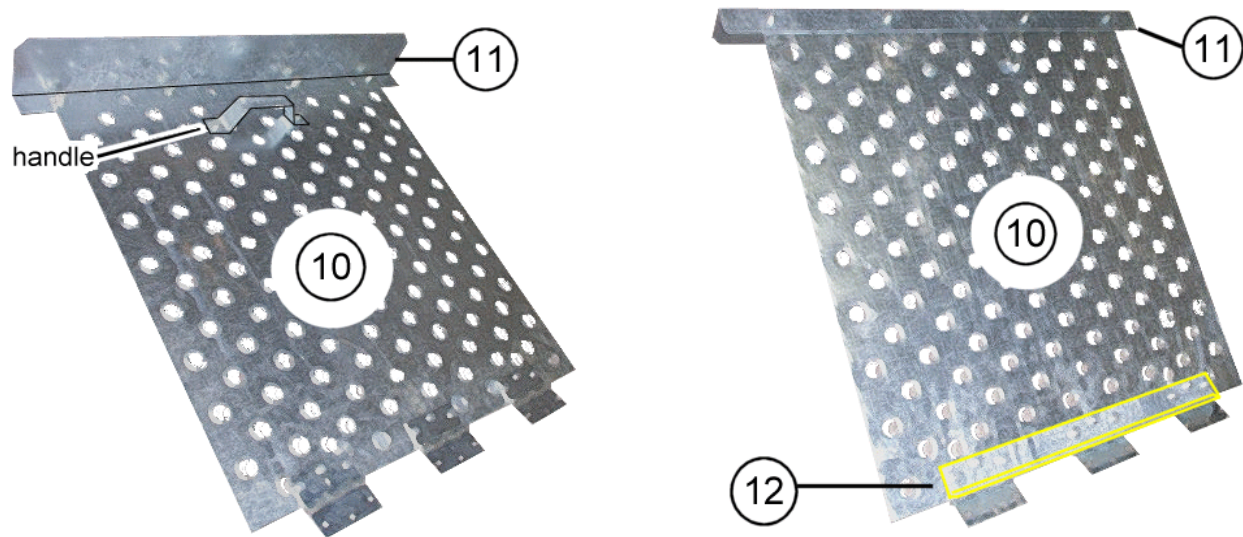

Step #4

Install the door assembly. Bolt the hinges to the floor. Use the second 18 ³/₄ @ hinge stiffener (12) on the underside of the floor.

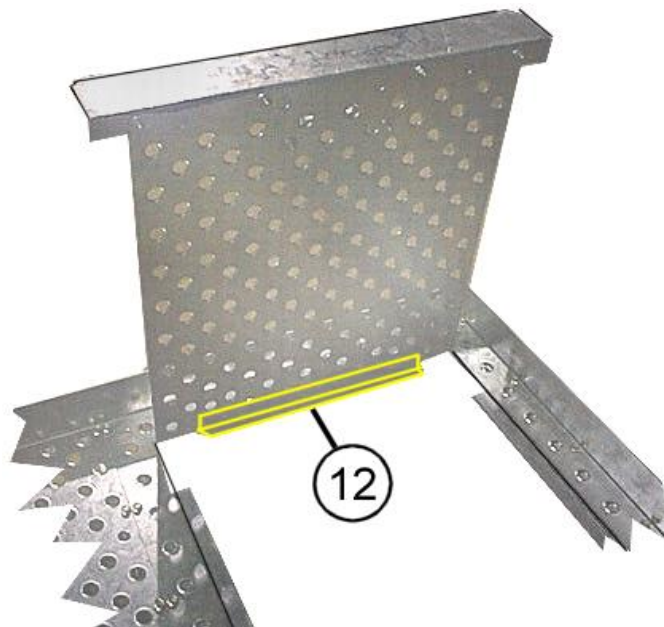

Step #5

Position the 38 ³/₈@x20" large floor panel (13) toward the front of the platform. Position the 26"x7 ¹¹/₁₆" small floor panel (14) at the motor end of the platform. Position the 26" rear platform toe board (15) and the 46 ¹/₁₆" side platform toe board (16). Using the row of holes closest to the trunk (on the outer C-channel), bolt through the floor panel, through the toe boards and through the C-channel.

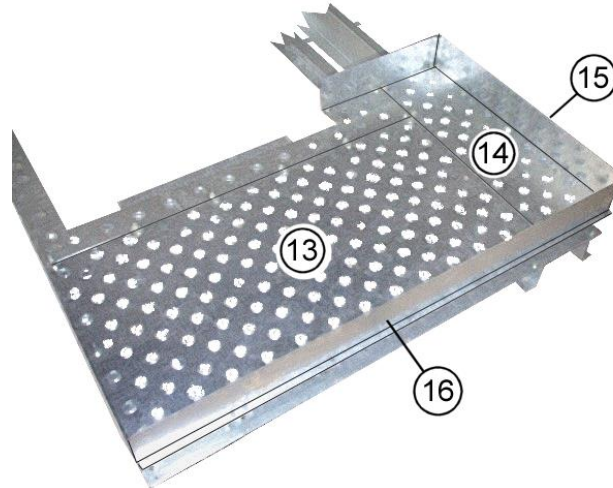

Step #6

Bolt to the insides of the toe boards the four 42" long railing uprights (17) and the two 23 ³/₄ @ short railing uprights (18). The two short uprights go on the motor side of the platform as shown. Bolt on the two 37 ⁷/₈@ door side hand rails (19), the two 51" front platform hand rails (20), the two 45 ⁹/₁₆" side platform hand rails (21), the 25 ¹/₂ @ rear platform hand rail (22), the 7 ¹/₈ @ motor side hand rail (23), and the 24 ³/₄ @ rear ladder hand rail (24).

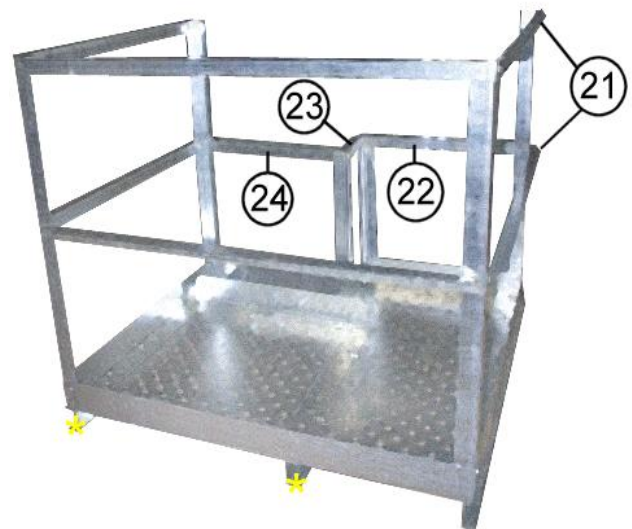
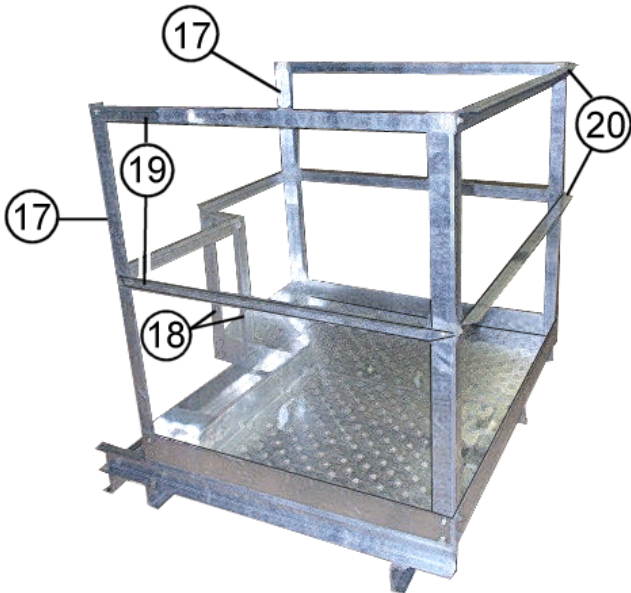

Note: □ At positions noted, bolt on kick braces. Extend them down and fasten the ends to the ladder channels below. This will require drilling a hole in the ladder channels or welding the connection.

Parts List Information

Ref #	Description	Length	Description	Quantity	Part #
1	Primary Support Channel	53"	C-Channel	2	hdpl4x3.105
2	Secondary Support Channel	46 5/16"	C-Channel	3	hdpl4x3.305
3	Floor/Door Support	18"	Angle	2	hdpl4x3.205
4	Door frame panel	38 3/8" x 31 1/2"	Flat Sheet	1	hdpl4x3.005-1
5	Door side toe board	38 3/8"	14	1	hdpl4x3.106-1
6	Front platform toe board	51 1/2"	10	1	hdpl4x3.110
7	Rear ladder toe board	25 5/16"	10	1	hdpl4x3.107
8	Short ladder toe board	7 1/4"	14	1	hdpl4x3.106-2
9	Long ladder toe board	14 5/16"	14	1	hdpl4x3.108-1
10	Door panel	27 7/8" x 25 1/4"	14	1	hdpl4x3.005-2
11	Door toe board	29"	14	1	hdpl4x3.111
12	Hinge stiffener	18 3/4"	10	2	hdpl4x3.104
13	Large floor panel	38 3/8" x 20"	14	1	hdpl4x3.006
14	Small floor panel	26" x 7 11/16"	14	1	hdpl4x3.007
15	Rear platform toe board	26"	14	1	hdpl4x3.108-2
16	Side platform toe board	46 1/16"	14	1	hdpl4x3.109
17	Long railing uprights	42"	10	4	hdpl4x3.905
18	Short railing upright	23 3/4"	10	2	hdpl4x3.906
19	Door side hand rail	37 7/8"	10	2	hdpl4x3.605
20	Front platform hand rail	51"	10	2	hdpl4x3.607
21	Side platform hand rail	45 9/16"	10	2	hdpl4x3.705
22	Rear platform hand rail	25 1/2"	10	1	hdpl4x3.600
23	Motor side hand rail	7 1/8"	10	1	hdpl4x3.606
24	Rear ladder hand rail	24 3/4"	10	1	hdpl4x3.805
25	Kick brace	45"	10	2	hdpl4x3.405
	bolt	3/4"	Grade 8	115	
	hex nut	--	--	115	