

Round Bottom Level Conveyor



ROUND BOTTOM LEVEL CONVEYOR

Head Features

- Computer aided modular bolt together design
- CNC manufactured
- 10-8-5 gauge standard galvanized construction
- Heavy duty pillow block bearings
- Heavy duty drive sprocket
- Removable inspection cover
- Dust seals

Trough Features

- Computer aided modular bolt together design
- CNC manufactured
- 10 gauge galvanized sides
- 10-8-5 gauge galvanized bottoms available
- UHMW return rollers
- Pre-assembled trunk sections
- Optional abrasion resistant steel liner for bottom and sides

Tail Features

- Computer aided modular bolt together design
- CNC Manufactured
- 10-8-5 gauge standard galvanized construction
- Heavy duty pillow block bearings
- Heavy duty sprocket
- Acme screw slack adjusters
- Removable inspection covers
- Dust seals



ROUND BOTTOM LEVEL CONVEYORS

Lambton Conveyor Limited

102 Arnold Street, Wallaceburg, Ontario, Canada, N8A 3P4

Tel: +1 519.627.8228 Toll Free: +1 888.239.9713 (North America)

Fax: +1 519.627.0250 Email: sales@lambtonconveyor.com

All specifications and designs are subject to change without notice due to continuous product improvement.

www.lambtonconveyor.com

Lambton is a trademark of Lambton Conveyor Limited

BPH	DRAG SIZE	RPM	FPM
1,000	GLR-09X9	37	64
1,500	GLR-09X9	55	95
2,000	GLR-09X9	74	128
2,500	GLR-09X9	92	160
3,000	GLR-09X9	109	189
3,000	GLR-09X17	31	95
4,000	GLR-09X17	41	126
5,000	GLR-09X17	51	158
6,000	GLR-09X17	61	189

	9 X 9	9 X 17	12 X 17	16 X 17
A	12	12	15	19
B	19	27	31	31
C	30	30	30	30
D	21	31	34	33
E	12	23	25	27
F (HEAD)	34.5	34.5	35.5	37
F (BOOT)	31.5	31.5	31.5	33.5
H	12	12	12	16
J	20	20	24	25.5
K	9.2	17.2	17.2	17.2
L	19	19	19	19
M	4.2	4.2	6	8
N	42	42	42	42
P	22.3	22.3	25	25
Q	36	40	42	42
R	33	33	33	33

*All dimensions are in inches intended for layout purposes
 *Standard trough sections are in 60" & 120" LG sections

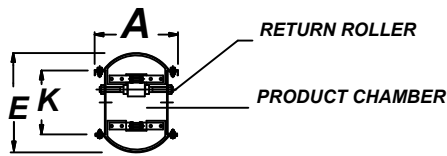
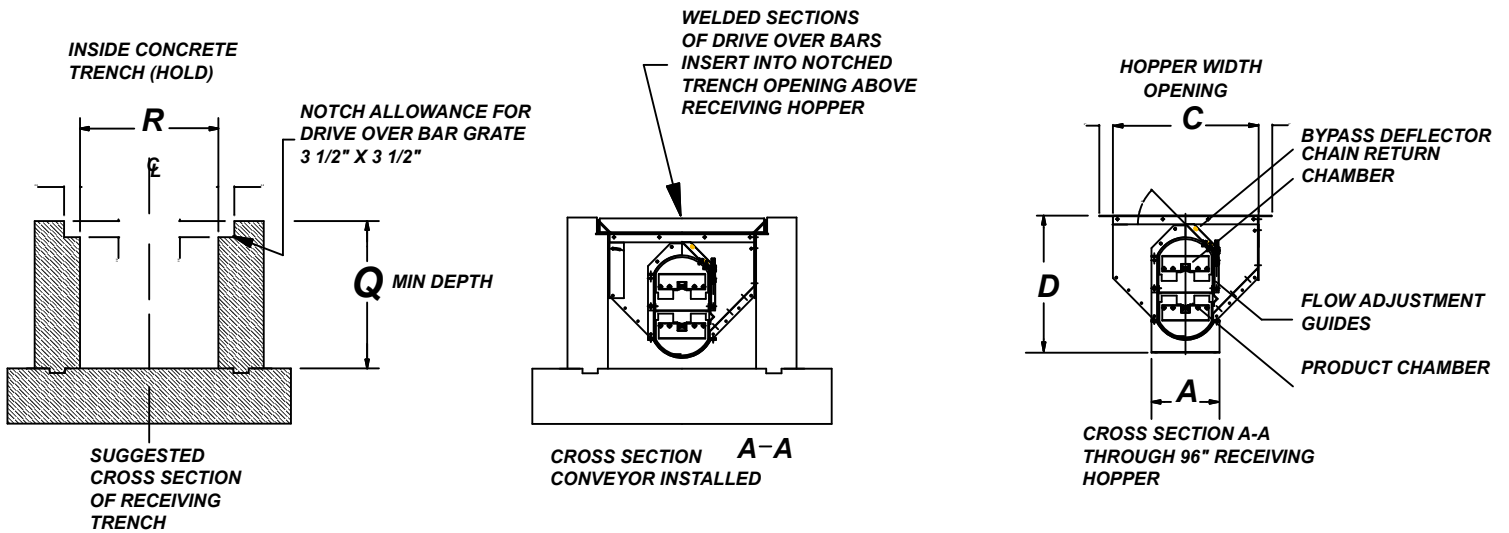

OPTIONAL RECEIVING HOPPER 96"
 ALSO 24", 48" & 144" LENGTHS
 AVAILABLE

