



DESIGNED FOR YOU
BUILT FOR YOU
SINCE 1965

DISTRIBUTORS



www.lambtonconveyor.com

DISTRIBUTOR

Dual Inlet Pendulum Distributor

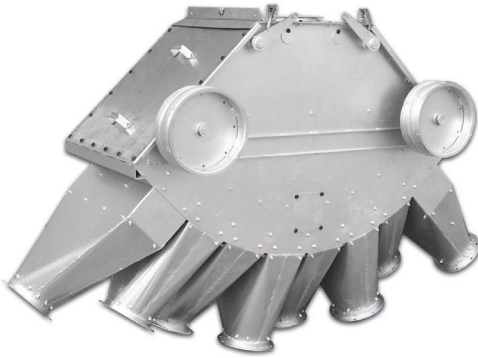

Features

- Large inspection door at each end
- Heavy duty long lasting construction
- Positive position locking
- Cable or electric actuated
- Easy turning (with sprocket & UHMW guide)
- Round flange inlet & outlets
- Short throat for limited loss of discharge height
- Standard abrasion-resistant steel liners in pendulum spouts
- Standard urethane liners in all pendulum discharge transitions



Swing spout contains a dense bristle brush to reduce dust and buildup while obtaining the highest level of product control.



Positive pendulum positioning is achieved through Lambton's high grade roller chain. Precision roller chain also reduces loss due to stretching.



Distributors come complete with controls for easy operation from ground level (control cable extra). Each set of controls is manufactured from galvanized steel. Each control wheel with handle comes with mounting brackets to fit any size leg trunk manufactured by Lambton Conveyor, allowing these controls to be mounted at any desired height.

Full Round Distributor



Features:

- Galvanized weather tight enclosure
- Large inspection door from top to bottom
- Heavy-duty long lasting construction
- Positive position locking
- Schedule 40 pipe for inner spout
- Inner spout brush ensures product control
- Cable or electric actuated
- Easy turning (with UHMW guide)
- Round flange inlet & outlets
- Short throat for limited loss of discharge height

Flat Back Distributor



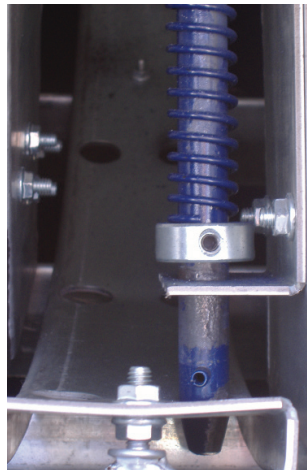
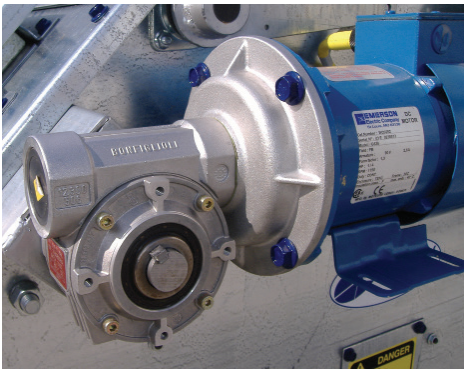
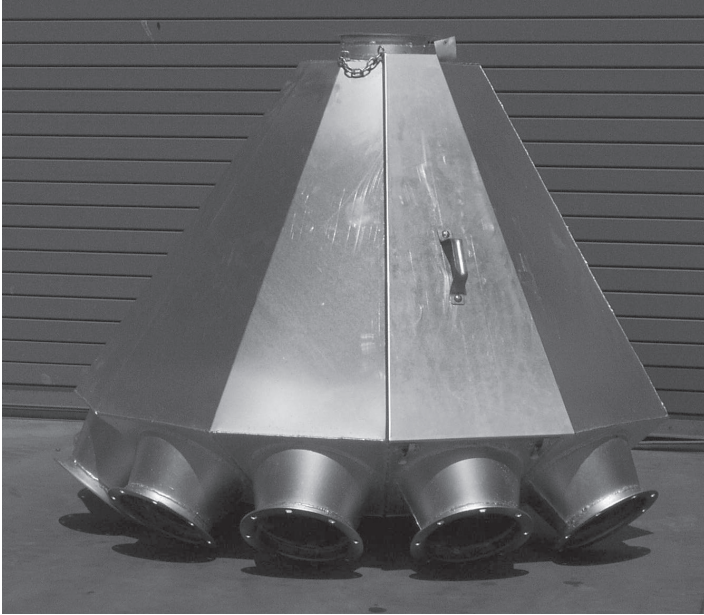

Electric Distributor Controller

The SG-383 combines state of the art touch screen technology and a durable DC drive control to offer outstanding performance. The entire process is being continuously monitored by the onboard CPU to ensure accurate positioning at all times.

Electric Controller Features

- One-touch control
- Bright display
- Easy set up
- Auto tuning
- Self-test feature
- High reliability
- 120V AC power

Electric Controller Options:

- Controls can be customized
- Cold climate package
- Catastrophic failure over-ride



The positive position distributor mechanism is unlatched by using your weight to depress a foot pedal and turning the spout is as easy as turning a steering wheel

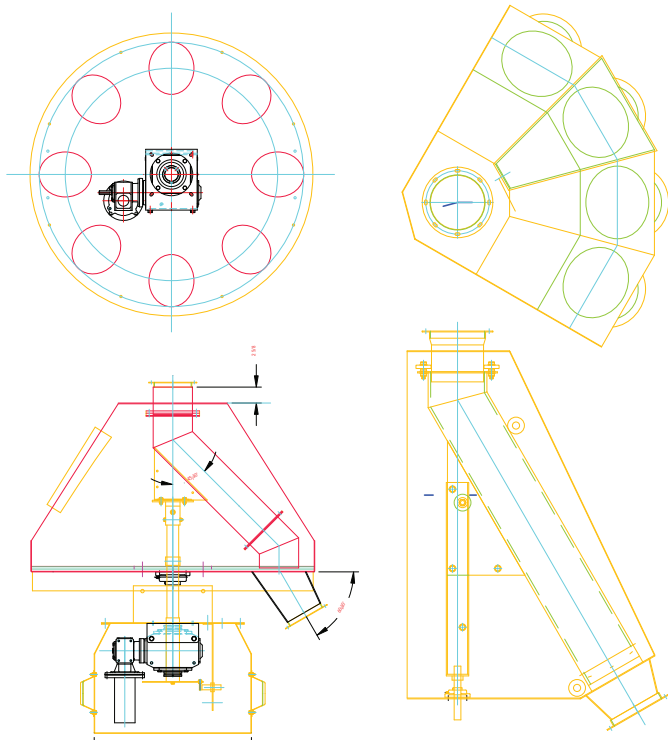

Full Round Distributor

Flat Back Distributor

FLAT BACK / FULL ROUND DISTRIBUTOR

Outlet Size	Height (H) (Inches)
6"	30 1/2
8"	41
10"	46 1/2
12"	52
14"	57 1/2

NOTE: Height is the same for 6, 8, 10, or 12 outlet models

Note: Heights are calculated from the top inlet to the bottom of the center outlet.

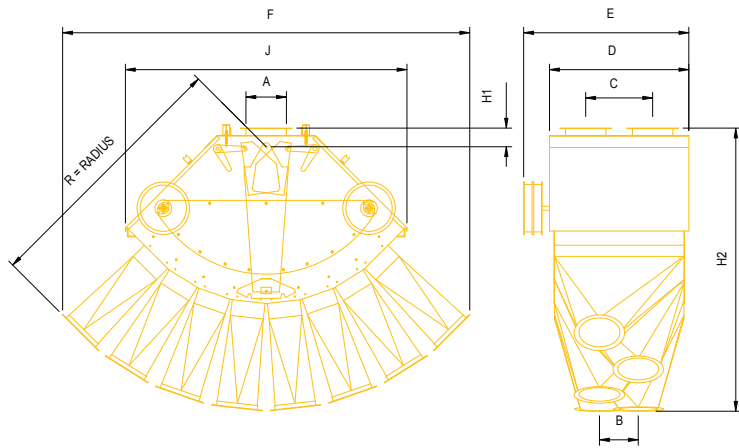

Dual Inlet Pendulum Distributor

Flowing Velocity

Diameter	BPH	Tons/Hour
6"	2122	59.4
8"	3773	105.6
10"	5887	164.8
12"	8482	237.5
14"	11550	323.4
16"	15082	422.3
18"	19087	534.4
20"	23565	659.8
22"	28507	798.2
24"	33930	950
26"	39817	1149

- Flowing velocity can be stated as grain flowing through a spout at a 45° angle for 10 feet or more, or approximately 875 to 1,000 FPM.
- This table could be utilized best for downspout size selection.
- Though it is to be kept in mind that as the grain flows down the spout the velocity increases and the grain stream occupies a smaller portion of the spout, thereby increasing the wear on the spouting.

6, 8, 10 OUTLET - 45° DUAL PENDULUM DISTRIBUTOR										
Outlet Size		A	B	C	D	E	F	J	H	R
Dia	Way									
8	6						76 1/8"	52"		48 11/16"
	8	8"	8"	13 3/4"	29 9/16"	35 3/4"	90 5/16"	65 15/16"	3 7/8"	58 5/8"
	10						104 1/16"	79 5/8"		68 5/16"
10	6						88 1/8"	56 1/8"		55 7/8"
	8	10"	10"	17"	36 1/8"	43 5/16"	103 7/16"	71 1/2"	4"	66 3/4"
	10						118 7/16"	86 3/8"		77 1/2"
12	6						94"	64 3/4"		58 15/16"
	8	12"	12"	19"	39 3/4"	45 7/8"	112 7/16"	83 1/8"	4 1/16"	72"
	10						131 11/16"	102 5/16"		85 5/8"
14	6						112 7/8"	73 1/2"		77 1/2"
	8	14"	14"	22"	43"	52"			4 7/8"	
	10									

Note: Heights are calculated from the top inlet to the bottom of the center outlet.

Our other range of products includes

Grain Bins



Bucket Elevator

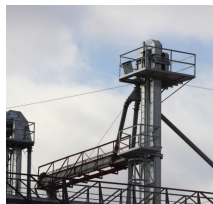

Hopper Bins

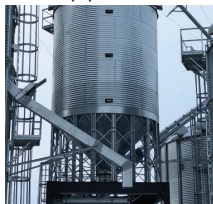

Catwalks

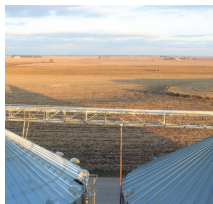

Distributors



Chain Conveyors

