

FLAT BOTTOM Level Conveyors



DESIGNED FOR YOU
BUILT FOR YOU
SINCE 1965



FLAT BOTTOM LEVEL CONVEYOR

Head Features

- Computer aided modular bolt together design
- CNC manufactured
- 10-8-5 gauge standard galvanized construction
- Heavy duty pillow block bearings
- Heavy duty drive sprocket
- Removable inspection cover
- Dust seals

Trough Features

- Computer aided modular bolt together design
- CNC manufactured
- 10 gauge galvanized sides
- 10-8-5 gauge galvanized bottoms available
- UHMW return rollers
- Pre-assembled trunk sections
- Optional abrasion resistant steel liners for bottom and sides

Tail Features

- Computer aided modular bolt together design
- CNC Manufactured
- 10-8-5 gauge standard galvanized construction
- Heavy duty pillow block bearings
- Heavy duty sprocket
- Acme screw slack adjusters
- Removable inspection covers
- Dust seals

Lambton Conveyor Limited

102 Arnold Street, Wallaceburg, Ontario, Canada, N8A 3P4

Tel: +1 519.627.8228 **Toll Free:** +1 888.239.9713 (North America)

Email: sales@lambtonconveyor.com

o change without notice due to continuous product improvement.

www.lambtonconveyor.com

Lambton is a trademark of Lambton Conveyor Limited

BPH	Drag Size	RPM	FPM
1,000	GLD-09X9	37	64
1,500	GLD-09X9	55	95
2,000	GLD-09X9	74	128
2,500	GLD-09X9	92	160
3,000	GLD-09X9	109	189
3,000	GLD-09X17	31	95
4,000	GLD-09X17	41	126
5,000	GLD-09X17	51	158
6,000	GLD-09X17	61	189
6,000	GLD-12X17	46	142
7,000	GLD-12X17	54	165
8,000	GLD-12X17	61	189
8,000	GLD-16X17	46	145
9,000	GLD-16X17	52	160
10,000	GLD-16X17	57	177
10,000	GLD-16X20	46	160
12,000	GLD-16X20	55	185
13,000	GLD-20X20	47	160
15,000	GLD-20X20	53	184
16,000	GLD-24X24	36	138
20,000	GLD-24X24	44	170
23,000	GLD-32X24	37	146
26,000	GLD-32X24	42	165
30,000	GLD-32X24	49	192

	9X9	9X17	12X17	13X11	16X17	16X20	20X20	24X24	32X24
A	9	9	12	13	16	16	20	24	32
B	9	17	17	11	17	20	20	24	24
C	31	31	31	31	31	31	31	35	43
D	25.5	25.5	27	25.5	27	30	30	36	36
E	9.25	17.25	17.25	11.25	17.25	20.25	20.25	27.25	27.25
F	24	30	30	24	30	42	42	48	48
G	9	8	8	6	8	8	8	12	12
H	10	10	12	12	16	20	20	24	32
J	13	20	20	16	20	24	24	28	28
L	19	19	19	20	19	19	19	24	24
M	3.5	3.5	3.5	3.5	3.5	3.5	3.5	3.5	3.5
N	42	42	42	42	42	42	42	42	42
P	20	20	20	20	20	20	20	20	20
Q	30	30	32	30	32	35	35	42	42
R	32	32	32	32	32	32	32	36	44

*All dimensions are in inches intended for layout purposes.
 *Standard trough sections are in 60" & 120" LG sections.

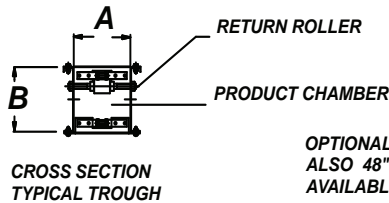
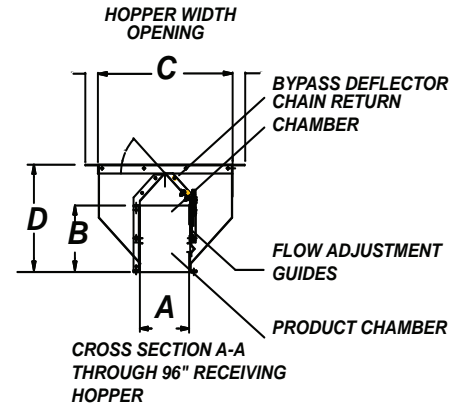
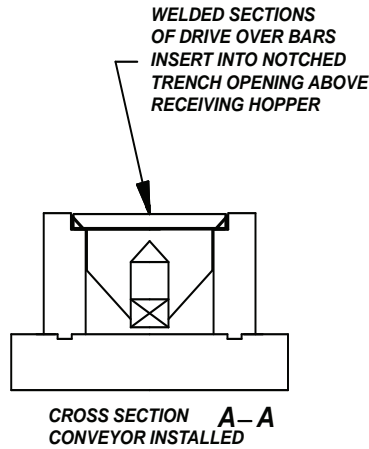
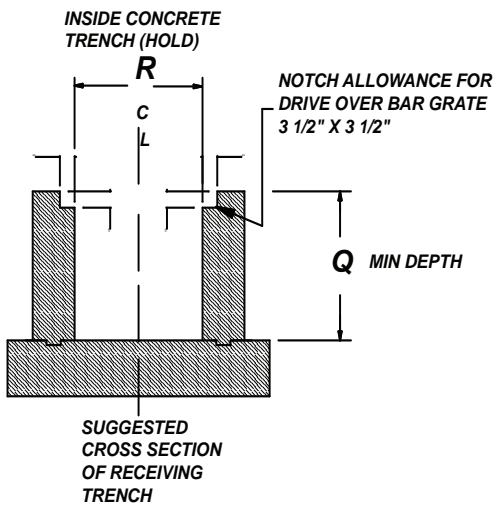

OPTIONAL RECEIVING HOPPER 96" ALSO 48" & 144" LENGTHS AVAILABLE

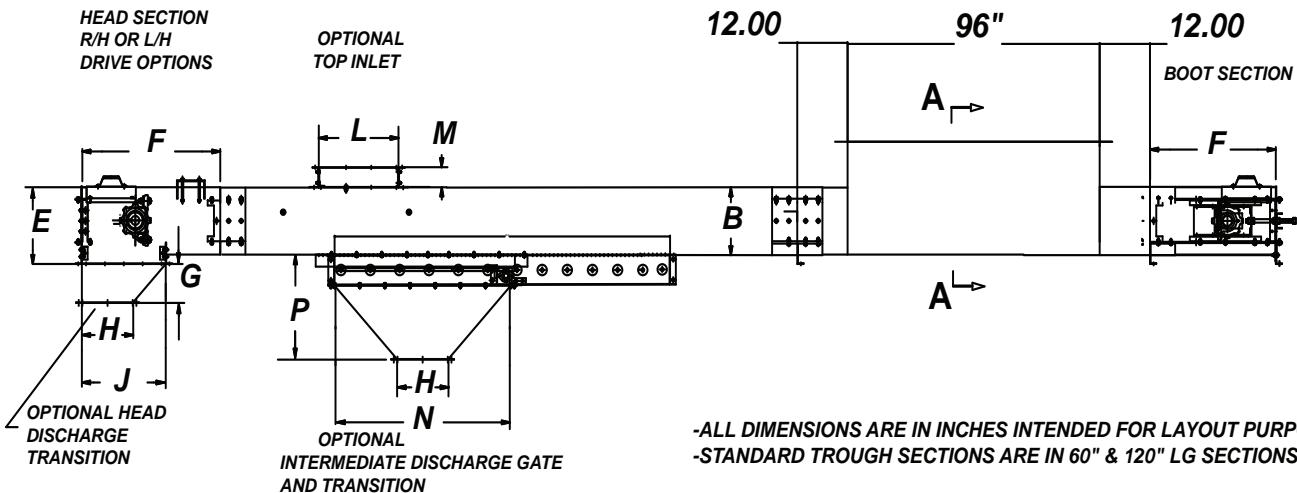

-ALL DIMENSIONS ARE IN INCHES INTENDED FOR LAYOUT PURPOSES.
 -STANDARD TROUGH SECTIONS ARE IN 60" & 120" LG SECTIONS