

FLAT BOTTOM

Low Profile Conveyors



DESIGNED FOR YOU
BUILT FOR YOU
SINCE 1965



FLAT BOTTOM LOW PROFILE CONVEYOR

Head Features

- Computer aided modular bolt together design
- CNC manufactured
- 10-8-5 gauge standard galvanized construction
- Heavy duty pillow block bearings
- Heavy duty drive sprocket
- Removable inspection cover
- Dust seals

Trough Features

- Computer aided modular bolt together design
- CNC manufactured
- 10 gauge galvanized sides
- 10-8-5 gauge galvanized bottoms available
- UHMW return rollers
- Pre-assembled trunk sections
- Optional abrasion resistant steel liners for bottom and sides

Tail Features

- Computer aided modular bolt together design
- CNC Manufactured
- 10-8-5 gauge standard galvanized construction
- Heavy duty pillow block bearings
- Heavy duty sprocket
- Acme screw slack adjusters
- Removable inspection covers
- Dust seals

Lambton Conveyor Limited

102 Arnold Street, Wallaceburg, Ontario, Canada, N8A 3P4

Tel: +1 519.627.8228 | Toll Free: +1 888.239.9713 (North America) | Email: sales@lambtonconveyor.com

All specifications and designs are subject to change without notice due to continuous product improvement.

www.lambtonconveyor.com

Lambton is a trademark of Lambton Conveyor Limited

BPH	DRAG SIZE	RPM	FPM
3,000	GLD-13X11	49	113
4,000	GLD-13X11	65	150
5,000	GLD-13X11	81	187
5,500	GLD-16X11	70	154
6,000	GLD-16X11	76	176
6,500	GLD-16X11	81	182
7,000	GLD-16X11	88	196

	9X9	13X11	16X11
A	9	13	16
B	9	11	11
C	31	31	31
D	25.5	25.5	25.5
E	9.25	11.25	11.25
F	24	24	24
G	9	6	9
H	9	12	16
J	13	16	16
L	19	20	20
M	3.5	3.5	3.5
N	42	42	42
P	20	20	20
Q	30	30	30
R	32	32	32

*All dimensions are in inches intended for layout purposes
 *Standard trough sections are in 60" & 120" LG sections

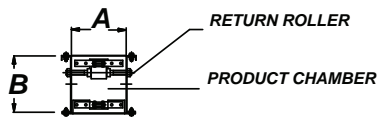
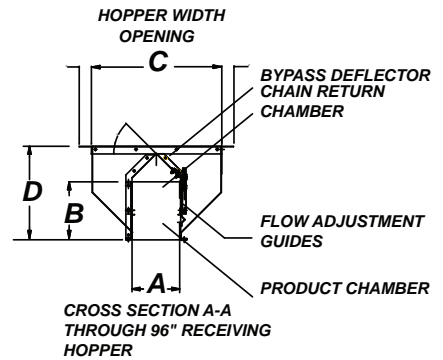
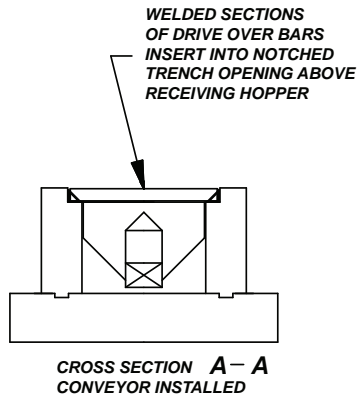
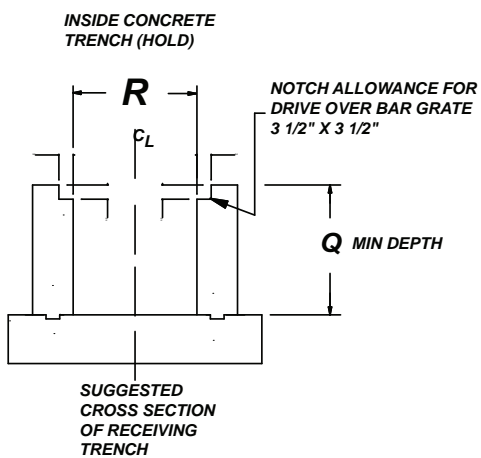

CROSS SECTION TYPICAL TROUGH

OPTIONAL RECEIVING HOPPER 96" ALSO 48" & 144" LENGTHS AVAILABLE

