



DESIGNED FOR YOU
BUILT FOR YOU
SINCE 1965

GRAIN LOOP



www.lambtonconveyor.com

Lambton is a trademark of Lambton Conveyor Limited



Receiving, conveying, bin unloading and load out all in one convenient and cost-effective system.

Use the **GRAIN LOOP** to update an existing site or integrate the system into new development.

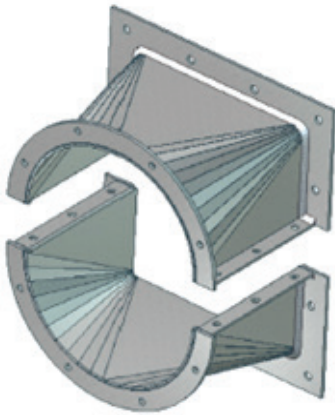

The most common wear point of the system are the transitions on the corners. Our unique split transitions allow for quick and easy replacement without having to break the chain

Tube Size	6" (15.2 cm)	8" (20.3 cm)	10" (25.4 cm)	12" (30.48 cm)
Maximum Capacity*	1,500 BPH 38 MTPH	4,000 BPH 102 MTPH	6,000 BPH 152 MTPH	10,000 BPH 254 MTPH
Chain Travel Speed	318 fpm 97 mpm	318 fpm 97 mpm	336 fpm 102 mpm	388 fpm 118 mpm
Head Shaft RPM	81	81	81	81
Tube gauge	12 GA 2.6 mm	10 GA 3.43 mm	10 GA 3.43 mm	10 GA 3.43 mm
UHMW paddle thickness	½" 12.7 mm	½" 12.7 mm	½" 12.7 mm	½" 12.7 mm
Conveyor Chain	81X	81XHH	81XHH	81XHH
Max. HP (kW)	30 (22)	60 (44)	100 (74)	120 (90)
Angle of Operation	Horsepower required per foot of conveyor. Kilowatt power required per meter of conveyor.			
Horizontal	0.042 0.103	0.076 0.186	0.114 0.279	0.178 0.435
Vertical section length and angle relative to vertical line.				
0° (straight line)	0.2 0.489	0.35 0.856	0.5 1.223	0.75 1.835
15°	0.193 0.472	0.338 0.827	0.482 1.179	0.724 1.771
30°	0.173 0.423	0.3 0.734	0.433 1.06	0.65 1.59
45°	0.141 0.345	0.247 0.604	0.353 0.863	0.53 1.296
Empty weight/FT (lbs)	12	19	23	27
Full Weight/ FT (lbs)**	21	35	48	62
Empty weight /m (kg)	18	28	34	40
Full Weight /m (kg)**	31	52	71	93
*Note that capacities are estimates only and that increased angle will reduce capacity. Capacities are based on 45 lb/ft ³ (721 kg/m ³) dry shelled corn.				
**Full weight is based on bottom tube full of 45 lb/ft ³ (721 kg/m ³) material				

FEATURES

- Gentle grain handling
- Split Sprockets
- Galvanized construction to ensure a long service life
- Spherical roller Bearings
- **Complete line of accessory equipment:**
 - o Intermediate discharge gates
 - o Transitions
 - o Catwalks and support towers
 - o Receiving hoppers and bin wells

Our other range of products includes

Grain Bins



Bucket Elevator



Hopper Bins

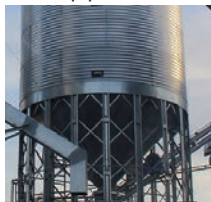

Catwalks



Distributors



Chain Conveyors



www.lambtonconveyor.com

Lambton is a trademark of Lambton Conveyor Limited

Lambton Conveyor Limited

102 Arnold Street, Wallaceburg, Ontario, Canada, N8A 3P4

Tel: +1 519.627.8228 | Toll Free: +1 888.239.9713 (North America) | Email: sales@lambtonconveyor.com

All specifications and designs are subject to change without notice due to continuous product improvement.