

## HEAD SECTION

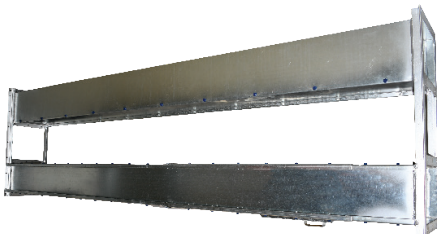

- G90 galvanized bolt-together design
- 10 GA, 8 GA and 5 GA galvanized construction
- 14 GA and 12 GA head cover splits for easy removal and inspection
- Internal 1/4" thick UHMW curved head liner with low impact operation and easy replacement.
- Slide lagged and crowned head pulley with tapered bushings
- Heavy duty pillow block roller bearings with vertical and horizontal adjustments
- Turned, ground and polished shaft
- Inspection door on both sides of head
- Dust protection at shaft opening
- Head lagging access door
- Various liner options are available including UHMW, abrasion Resistant steel and urethane
- Optional Head Vent
- We use standard UHMW liners as seen. Abrasion resistant steel and ceramic chip are available upon request. Adjustable bucket flapper also provided

## TRUNKING



- G90 galvanized bolt together design
- 14 GA, 12 GA, 10 GA bolted construction
- Removable side panel for inspection
- Structural angle Flanges are welded to trunk using only silicon-bronze MIG wire to prevent corrosion and extend the utility of the bucket elevator
- Sections are fully assembled from the factory (no tie-angles) to allow for quick assembly on site (Note, this is only 36" pulley models and below)
- Vented options available

## BOOT SECTION

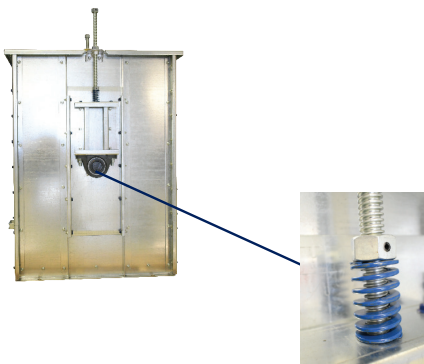

- G90 galvanized bolt-together design
- 10 GA, 8 GA and 5 GA galvanized construction
- Vertical stiffening angles in frame of boot to give more strength and rigidity
- Heavy-duty pillow block ball bearings
- Die springs on belt take-up assembly ensures proper tensioning of belt for better traction and longer life
- Turned, ground and polished shaft
- Acme rod take-up for belt adjustment for easy installation
- Dust protection at shaft opening
- Bolted clean out doors at the base of boot
- Boot shaft tapped for optional speed sensor
- Cleanout drawer and self cleaning options are both available

MODEL #	BPH	TPH	MTPH
GLC-05-4X3-08	225	6.3	5.7
GLC-05-4X3-07	255	7.1	6.5
GLC-05-4X3-06	300	8.4	7.6
GLC-05-4X3-05	360	10.1	9.1
GLC-05-4X3-04	450	12.6	11.4
GLC-09-6X4-06	750	21	19.1
GLC-09-6X4-05	900	25.2	22.9
GLC-16-9X5-12	1,550	43.4	39.4
GLC-16-9X5-09	2,100	58.8	53.3
GLC-16-9X5-06	3,100	86.8	78.7
GLC-24-9X6-08	3,400	95.2	86.4
GLC-24-9X6-07	3,900	109.2	100
GLC-24-11X7-09	5,000	140	127
GLC-24-11X7-08	5,700	159.6	144.8
GLC-30-9X6-10	3,000	84	76.2
GLC-30-9X6-09	3,400	95.2	86.4
GLC-30-9X6-08	3,800	106.4	96.5
GLC-30-9X6-07	4,400	123.2	111.7
GLC-30-11X7-10	5,200	145.6	132
GLC-30-11X7-09	5,700	159.6	144.8
GLC-30-11X7-08	6,500	182	165
GLC-36-12X7-11	5,900	165.2	149.8
GLC-36-12X7-10	6,400	179.2	162.5
GLC-36-12X7-09	7,000	196	177.7
GLC-36-12X7-08	8,000	224	203
GLC-36-12X8-9.5	9,000	252	228.6
GLC-36-12X8-8.5	10,000	280	254
GLC-42-16X8-12	10,000	280	254
GLC-42-16X8-10	12,000	336	304.7
GLC-42-16X8-09	13,500	378	342.8
GLC-42-18X8-10	13,900	389	353
GLC-42-18X8-8.5	16,300	459	416.5
GLC-42-20X8-8.5	18,400	515	467.3
GLC-42-20X8-07	20,000	560	507.9
GLC-42D-16X8-10	24,000	672	609.5
GLC-42D-16X8-09	27,000	756	685.7
GLC-42D-18X8-8.5	32,000	896	812
GLC-42D-20X8-8.5	36,000	1,008	914
GLC-42D-20X8-07	40,000	1,120	1,015

DIMENSION	05 - 4X3	09 - 6X4	16 - 9X5	24 - 11X7
A	27	42	52	65
B	28	38	42	52
C	0	0	23	28
D	28	38	65	81
E	13	16	19 3/4	24
F	12	14 3/4	14 1/4	18
G	8 1/2	9 1/2	13	16
H	12 5/8	17 1/2	17	21
I	14	21 5/8	9	11
J	1 1/8	1 1/2	7/8	1
K	N/A	N/A	12 1/4	15
L	16 1/2	24 1/2	36	45
M	4	7	8 3/4	11
N	12	11 1/2	18 1/4	22
O	20 7/8	25 3/8	39	49
P	6	12	12	15
Q	6	12	12	15
R	14 7/8	17 1/4	18 1/4	22
S	15	22	32	41
T	N/A	12	12	15
U	8 1/2	11 3/4	15 1/2	19
V	6	9	12 1/2	16
W	9	12	16 1/2	21
X	12 1/2	16	20	25
Y	60 or 120	33 1/2	45 1/4	56
Z	36	36	36	45
AA	N/A	6	12	15



- CAPACITIES ARE EXAMPLES BASED ON CENTRIFUGAL DISCHARGE SPEEDS FOR WHOLE GRAINS.
- CAPACITIES ARE BASED ON 56# SHELLED CORN OR GRAIN SORGHUM @ 15.5% MOISTURE.
- SLOW CENTRIFUGAL AND GRAVITY DISCHARGE SPEED CAPACITIES ARE AVAILABLE UPON REQUEST.

# BUCKET ELEVATORS

						2 ROWS OF BUCKETS		
1-9X6	24 - 11X7	30 - 9X6 / 11X7	36 - 12X7 / 12X8	42 - 16X8	42 - 18X8 / 20X8	42D - 16X8	42D -18X8	42D -20X8
60	69 1/2	88 1/4	95 3/4	109 1/4	109 1/4	109 1/4	109 1/4	109 1/4
51 3/4	63	77 3/4	77 3/4	94 1/4	94 1/4	94 1/4	94 1/4	94 1/4
19	14 3/4	3 3/16	6 1/2	0	0	0	0	0
70 3/4	77 3/4	80 15/16	83 3/4	94 1/4	94 1/4	94 1/4	94 1/4	94 1/4
N/A	N/A	N/A	N/A	83	83	83	83	83
N/A	N/A	N/A	N/A	N/A	N/A	N/A	N/A	N/A
13 1/2	13 1/2	19	19	18 5/8	18 5/8	18 5/8	18 5/8	18 5/8
16 3/4	23	34 3/16	34 3/16	39 7/16	39 7/16	39 7/16	39 7/16	39 7/16
9	11 1/4	11 1/4	12	14	14	14	14	14
7/8	7/8	7/8	7/8	1 3/4	1 3/4	1 3/4	1 3/4	1 3/4
20 1/4	18 1/4	26 1/4	32 1/4	38 1/4	38 1/4	38 1/4	38 1/4	38 1/4
44	46 1/2	54 1/8	62	70	70	70	70	70
8 3/4	8 3/4	12	12	12	12	12	12	12
18 1/4	21 1/2	24 3/4	27	23	23	23	23	33
39	41 1/2	52 3/4	55	52	52	52	52	52
12	12	16	17	17	17	17	17	17
12	12	16	17	17	17	17	17	17
18 1/4	20 3/4	24 3/4	27	23	23	23	23	23
40	43 3/4	50 13/16	58	70	70	70	70	70
12	12	12	12	12	12	12	12	12
15 1/2	18	18	21	23	29 3/4	44	48	52
12 1/2	15	15	17	20	26	39 5/8	43 5/8	47 5/8
18 1/2	20	20	23 3/4	27 1/2	35 1/2	47 3/16	51 3/16	55 3/16
20	24 1/4	24 1/4	30 1/4	33 1/4	41 1/4	54 11/16	58 11/16	62 11/16
45 1/4	45 1/4	56 5/8	56 5/8	65 1/2	65 1/2	65 1/2	65 1/2	65 1/2
36	36	36	36	36	36	36	36	36
12	12	12	12	13 1/2	13 1/2	13 1/2	13 1/2	13 1/2

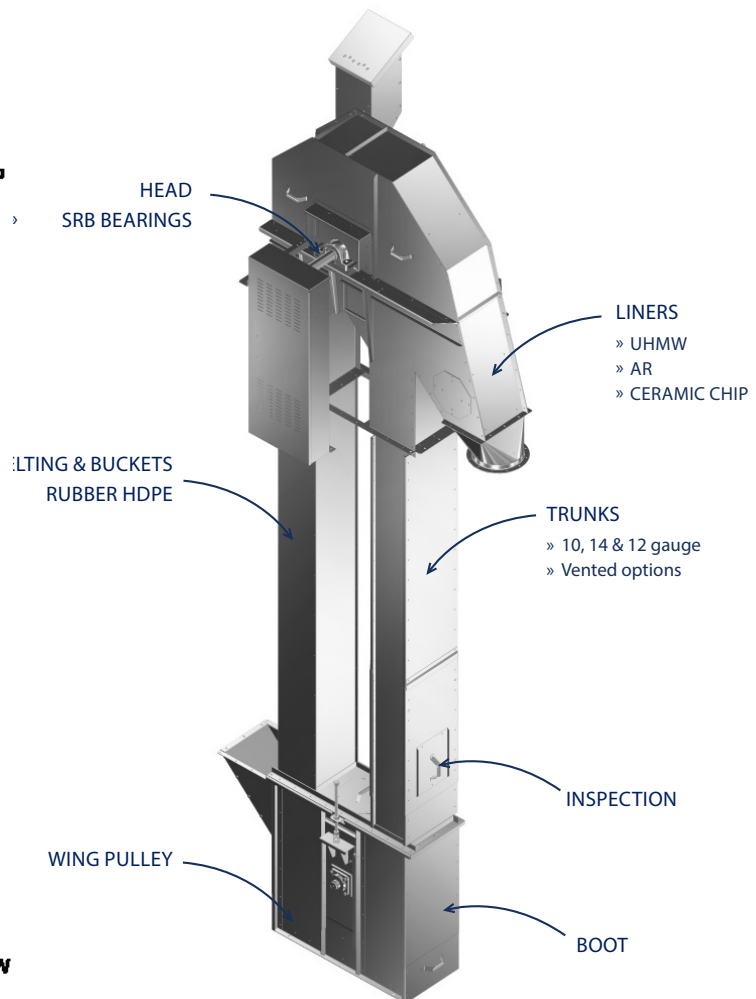
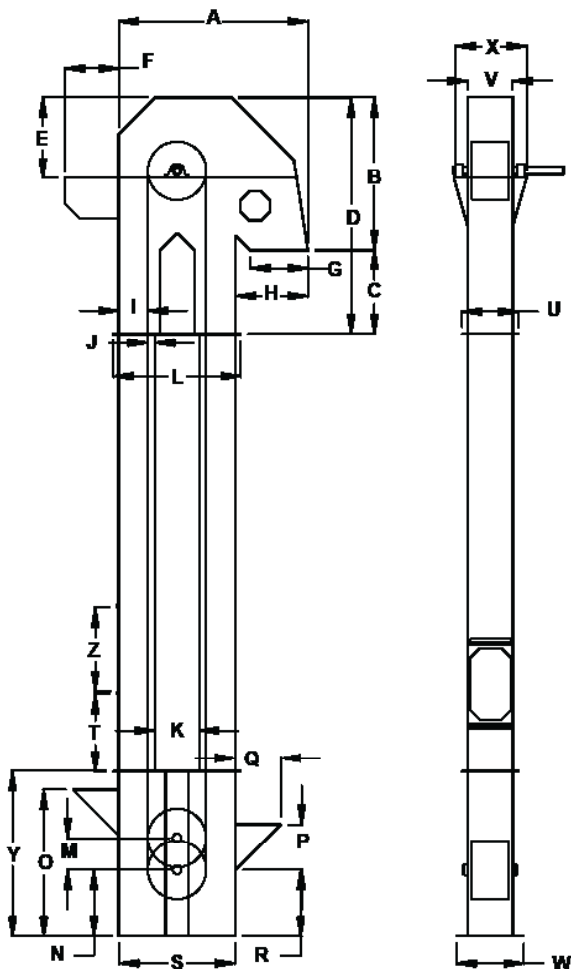



## STANDARD FEATURES

### Bearings

Lambton offers Pillow Block Double Row Spherical Roller Bearings as standard for head shaft sizes 1-15/16" and larger. SAF or Adaptor Mount Bearings are optional and available upon request.

### Buckets

We use durable, non sparking, polyethylene buckets as standard. Steel, Nylon or Urethane buckets are optional for rough and abrasive materials

### Boot Pulley

Standard heavy-duty wing pulley included with XT bushings, optional herring bone wing pulley available upon request

### Head Pulley

Standard slide lagged and crowned head pulley with tapered bushings

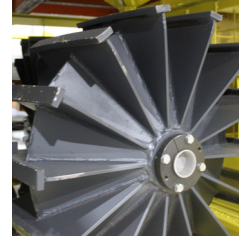
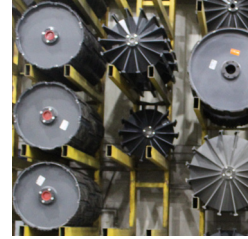

### Elevator Belting

In order to provide the best product to fit customer specifications, our Bucket Elevator comes with standard belting. Optional PVC belt is available upon request



### Liners

We use standard UHMW liners as seen. Polypropelene, abrasion resistant steel and ceramic are available upon request. Adjustable bucket flapper is also provided.



## STANDARD FEATURES

### Platforms

Lambton offers standard platform and ladder packages to allow easy access to your equipment with optional safety cage, rest platforms, work platforms and head platforms. Each platform includes full hand rail set as well as a large swing door in the floor for fall protection.

Custom platforms are available upon request



### Distributors & Flow Accessories

We offer distributors in Full Round, Flatback and Dual Inlet Pendulum types. Flow System Accessories include Cushion Boxes, Reducers, Valves among many others

